

START NORGE AS ELECTRIC AVIATION IN NORWAY

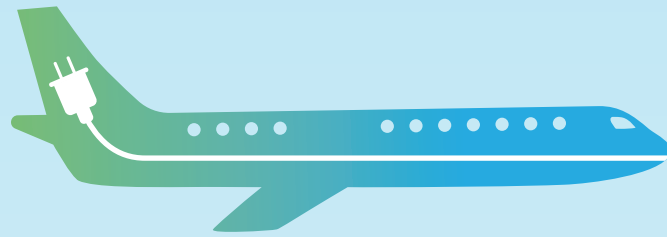

STAVANGER

BERGEN

FEASIBILITY STUDY BY GREEN FUTURE AS

AUTHOR: JAN OTTO REIMERS

OCTOBER 2020

FEASIBILITY STUDY ASSIGNED BY: START NORGE AS

ACKNOWLEDGMENT

This study was prepared by Green Future AS, based on a first version assigned by Avinor in 2018. The project manager was Jan Otto Reimers. Adam Hadhazy provided editorial assistance. The text was based on public sources including white papers, research papers, books, news media articles, journal perspective articles, interviews with companies and stakeholders, and more. Avinor, Siemens, Rolls Royce, Bauhaus Luftfahrt, Flying Pages, Pipistrel, Zunum, Ampaire, Heart Aviation, Widerøe, Eviation, Uber Elevate, Bell Helicopter, Airbus, and NASA are thanked for their support during the preparation of this study. Alessandro Sgueglia, an electric propulsion engineer with Aura Aero, provided analysis for energy consumption during a flight from Bergen to Stavanger.

GREEN FUTURE AS

Green Future AS provides advisory services and analyses evaluating future development trends and strategies for technologies including renewable energy, energy management, battery powered drive systems, wireless communication, Internet of things, and autonomous systems.

START NORGE AS

Start Norge AS is a nonprofit company formed by Aircontact Group AS, Berg-Hansen Reisebureau, Avinor AS and Næringsforeningen i Stavanger-regionen.

The nonprofit company's purpose is to facilitate an appropriate framework for an early phasing-in of electric aircraft in commercial aviation in Norway in order to make the country a guiding force for environmentally friendly aviation.

The following activities will be pursued:

- Investigate the effects of an early phasing-in of electric aircraft for Norway, socially as well as commercially.
- Facilitate the establishment of appropriate governmental support schemes for the purchase of electric aircraft.
- Facilitate the establishment of the necessary infrastructure for the operation of electric aircraft; for example, the appropriate charging options for the aircraft.
- Be the driving force for authorities to introduce various incentives for both airlines and passengers to choose electric aircraft as their preferred means of transport, e.g. financial incentives such as tax relief.

AIRCONTACT GROUP AS

Aircontact Group is a privately owned holding company within the travel, aviation, support services, offshore, and biotechnology sectors. The company's flagship, Berg-Hansen Reisebureau, is the largest business travel agency in Norway and is internationally affiliated with the prestigious Carlson Wagonlit Travel.

The air brokering unit, Aircontact, is the largest air broker in Scandinavia and the oldest in Europe, delivering tailor-made charter solutions for governments and businesses.

Aircontact Group is also a Nordic regional sales and marketing consultant for Sikorsky Aircraft, Lockheed Martin, Dercos Aerospace, Collins Aerospace, and General Dynamics European Land Systems employing 478 people across the Nordics with an annual gross turnover of NOK 5.2 billion.

BERG-HANSEN REISEBUREAU AS

Berg-Hansen Reisebureau is Norway's largest business travel agency, supplying all types of travel services including corporate travel, group travel/events, leisure travel, vacation package deals, and more. Berg-Hansen handles the total travel arrangements for many of Norway's largest companies and public service agencies. Citing sustainability as the key for the travel industry, Berg-Hansen is moving forward to position themselves as a driver in the travel industry for sustainable thinking and actions.

AVINOR AS

Avinor AS (Avinor) is a wholly owned state limited company under the Norwegian Ministry of Transport and is responsible for 44 state-owned airports.

Avinor has taken a leading role in reducing climate gas emissions from the aviation industry, including development of electrified aircraft and promoting sustainable jet biofuel.

Avinor provides safe and efficient travels for around 50 million passengers annually, half of which travel to and from Oslo Airport.

Avinor is financed via airport charges and commercial sales. The air navigation services is organized as a subsidiary wholly owned by Avinor.

NÆRINGSFORENINGEN I STAVANGER-REGIONEN

The Stavanger Chamber of Commerce and Industry is Norway's largest chamber and business organization. Since its establishment in 1836, the organization has worked for its member companies, ensuring that the region has the attributes needed to make it a preferred region to live and work in. The Stavanger Chamber of Commerce and Industry is the region's largest organizer of business meetings and seminars. The organization publishes the business magazine Rosenkilden and offers a variety of products to the business sector.

DISCLAIMER

Green Future AS takes no responsibility for statements, assumptions, conclusions or other information in this study that may not be correct. All information in this study is based on publicly available sources and interviews with individuals and companies. Some statements are based on Green Futures' views, expectations or assumptions on future development that may involve known as well as unknown risks, and which may change the future outcome significantly.

SUMMARY AND CONCLUSIONS

This study is an updated version of a previous study by Green Future AS from March 2018 that presents the opportunities that the electrification of aviation may contribute to future sustainable and low-emission aviation in Norway. This updated study for Start Norge contains most of the same topics with updates but also includes a new section examining a scenario for electric commercial flights between Stavanger and Bergen on the west coast of Norway.

The electrification of aviation is high on the political agenda in Norway and a number of activities have taken place since the first project started in 2015, when Avinor and the Norwegian Air Sports Organization (NLF) started participation in a long-term project exploring electrification's possibilities. Among the activities was acquiring an electric two-seater Pipistrel Alpha Electro to gain practical experience of electric aviation.

The study by Green Future from March 2018 was accompanied in March 2020 by a report entitled "Proposed program for the introduction of electrified aircraft in commercial aviation in Norway" from Avinor and The Civil Aviation Authority of Norway (Luftfartstilsynet). The Ministry of Transport has communicated that this proposed program, together with other relevant papers, will be the basis for a policy for the electrification of aviation to be included in the upcoming National Transport Plan (NTP) to be released in the spring of 2021. However, the Government may put forward proposals relevant to electrification of aviation before the new NTP is presented.

Summary of Key Points

More than 20 destinations/routes in the Norwegian short airfield network have distances ranging from 38 – 170 km, all of which can easily be flown by a battery-powered electric aircraft. The first electric aircraft to operate in this network is likely to be configured as a hybrid electric (that is, an electric aircraft with a standard mode of a fuel-powered generator as a backup electricity source), but will be capable of being operated via electric power only. For a few destinations, the aircraft can continue to the next airport or return to its origin without charging and still fly using electric power only because the overall distances flown are fairly short. With the flexibility provided by the hybrid electric aircraft approach, the implementation of electric aviation can be made step-by-step, thus reducing the risks of irregularities during the introduction phase.

Within a timeframe of 10 – 15 years, battery technology will offer sufficient capacity for pure electric aircraft to accommodate approximately 1-hour flights or more than 500 km. When implemented, this electric transport option would have wide-ranging and immediate impacts, considering that most of the flights in the Norwegian short airfield network—initialised as FOT in Norwegian and PSO (Public Service Obligation) in English—cover distances of less than 200 km. (Flights in the PSO routes network receive government subsidies to maintain the routes as the passenger numbers are insufficient for commercial operation.)

Technology development for electric aircraft is advancing steadily and has broad support in the aviation industry, involving leading manufacturers such as Boeing and Airbus, in addition to major suppliers including Rolls Royce, Safran, and a range of new ventures who are leading in many sectors. A number of aircraft projects are under development that are targeted to enter into service by the early, mid, and late 2020s. A surprisingly high number of projects supported by investments worth billions of dollars are vertical take-off and landing (VTOL) aircraft, also referred to as flying taxis. A number of projects for sport aircraft are also in development. Several projects for commercial regional or commuter aircraft are progressing as well, along with more futuristic projects and activities looking at different approaches for electrification of larger aircraft.

Much of the progress in setting the stage for the electrification of aviation directly relates to the rapid development of batteries and electronics pursued by the automotive industry over the last couple decades. The increasing range, lowering costs, and growing customer appeal in the electric automobile sector since the introduction of the first mass-market hybrid electric vehicle, the Toyota Prius in the 1990s, are all trending toward wider adoption of electric transportation technologies.

Beyond batteries, whose charge capacity and performance are all anticipated to continue markedly improving year-on-year, there are no major technical obstacles for hybrid and even all-electric aircraft seating up to 100 passengers. The first pure electric two-seater aircraft are already in production and operation. These electric light aircraft are expected to be eagerly adopted for pilot training due to their significantly lower operational costs, reduced noise, and zero local emissions. Small airfields will welcome electric aircraft because they will economically enable increased aviation activity, yet with less disturbance to the surrounding community. Regional hybrid electric aircraft with 6 – 19 seats may be available around 2025, while aircraft with 20- to 70-seat capacities may be entering commercial operation in various countries within 10 years. For larger regional aircraft the timeframe may be 15 – 20 years, and for long haul intercontinental flights it is likely that there will be new hybrid solutions where batteries and electric motors reduce fuel consumption and increase overall efficiency.

Let us enumerate and look at these advantages of electric aviation in further detail:

- **Reduced emissions.** There is the potential to reduce the emission of approximately 1,3 mill tons of CO₂ equivalents if all domestic air transportation in Norway converts to electric power. Converting to electricity eliminates emissions of greenhouse gases as well as nitrous oxides (NO_x), hydrocarbons, and particulate matter. In the case of Norway, 98% of the country's electricity is generated via hydropower, ensuring that the batteries' electricity comes almost solely from a renewable source.
- **Reduced energy consumption.** An electric motor is much more efficient than a fuel-burning engine. In general terms, the electric motor is more than 3 times as efficient at converting electricity to shaft power versus fossil fuel. The combustion of hydrocarbons does release considerably more energy, but much of that energy is wasted as heat compared to the energy generated by an electric motor.
- **Noise reduction.** Electric motors produce significantly less noise compared with the combustion inherent to fuel-burning engines. Electric motors combined with the new development of efficient, low-pressure ducted fans for aircraft serving 20 – 100 passengers may reduce noise significantly compared with a similarly sized, conventional turboprop aircraft.
- **Short-field operation.** Electric motors are light, responsive, and can be designed to provide extra power boosts for acceleration to enable take-offs on short runways and reversed thrust for rapid slow down after landing.
- **Reduced cost for maintenance and operations.** Scheduled engine maintenance for electric aircraft is expected to be significantly reduced and unplanned repairs similarly reduced compared to conventional aircraft, thus vastly reducing costly aircraft out-of-service time. The electricity cost may be lower than the cost of today's fuel. The additional cost for the amortization of batteries is highly dependent on the cycle life of future batteries.
- **Vertical take-off and landing.** The scalability of electric motors may also allow new aircraft designs with multiple motors permitting vertical take-off and landing capabilities. A number of innovative projects for short haul (less than 100 km) air transport, akin to an air taxi, are under way for 1- to 4-seater aircraft and may reasonably be in commercial operation within 5 years. This type of technological approach could ultimately make sense for larger aircraft as well if it can be combined with a lift-based and less energy-consuming cruise mode.

Conclusions

This study concludes that new aircraft with electric propulsion are suitable for regional flight routes in Norway.

Among several other short distance routes in Norway, the 180 km distance route between Stavanger and Bergen is particularly ideal for electric flight with both the Haugesund and Stord airports situated along the route in order to fulfil operational requirement for alternate landing fields.

The battery technology of today is sufficiently capable to store electric power for scheduled flights between Stavanger and Bergen. More than 20 other short destinations/routes in Norway may be easily flown by electric aircraft.

The first commercial electric aircraft are expected to be hybrid electric in order to provide more flexibility and accommodate the mandatory energy reserve for such commercial operations.

Norway is well-positioned to be a pioneer in this nascent field because of the availability of renewable hydropower and a well-structured network of short field airports owned by Avinor. The government may accelerate such early adoption in Norway via several instruments that can be structured to encourage the operation of electric aircraft.

In this matter, time is of essence. Each year earlier that the start of transition to electric aviation is moved up will save a significant amount of emissions—approximately 1,3 mill tons CO₂ emission equivalents per year.

Table of Contents

Acknowledgment	1
Green Future AS	1
Start Norge AS.....	1
Aircontact Group AS.....	1
Berg-Hansen Reisebureau AS.....	2
Avinor AS.....	2
Næringsforeningen i Stavanger-regionen	2
Disclaimer	2
Summary and conclusions.....	3
1. Introduction.....	9
2. Scope	10
3. Methodology	10
4. Government policies.....	11
5. Electric Aircraft – How do they work.....	12
5.1 Why electric?	15
6. Certification	15
7. Battery status	16
7.1 Battery producers	17
LG Chem	19
CATL - Contemporary Amperex Technology Ltd.....	19
BYD	20
Samsung SDI	20
Panasonic.....	20
Northvolt	20
7.2 Norwegian battery activities.....	21
FREYR.....	21
Morrow Batteries	21
Beyonder	21
Graphene Batteries.....	21
Siemens	22
Corvus Energy	22
Hydro Volt.....	22
Elkem	22
7.2 Battery development	23
7.3 Fast charging	24
7.4 Thermal control.....	25
7.5 Battery swapping systems	25
7.6 Battery lifetime	25

7.7 Limited supply of raw materials for battery production	26
8. Alternatives to batteries	27
9. Industry activity and projects	27
9.1 Commercial aircraft	28
Boeing	29
Airbus	30
ATR	32
Bombardier	33
Embraer	33
Textron Group	34
9.2 Regional aircraft projects	35
Zunum Aero	36
Eviation	37
Ampaire	39
Pipistrel	40
Aura-Aero	41
Heart Aerospace	41
Daher	42
Electra.Aero	43
Voltaero	44
Others	45
9.3 Research projects	45
Bauhaus Luftfahrt	45
DLR (Federal Republic of Germany's research centre)	48
Onera	50
NASA	50
9.4 Urban air transport	52
Airbus – City Airbus	53
Uber Elevate	54
Others	55
9.5 Light sport aircraft	55
Pipistrel	55
Equator Aircraft Norway	56
Bye Aerospace	57
Other projects	58
10. Technology	58
10.1 Electric propulsion systems	58
Ducted fans	59

Boundary layer ingestion	61
Distributed propulsion.....	63
Open rotor system.....	66
Propellers.....	66
Wingtip mounted propulsion	67
10.2 Drive systems and electric motors	67
Rolls-Royce	68
Safran.....	70
MGM Compro.....	71
General Electric	72
Magnix.....	72
Emrax.....	73
10.3 Hybrid electric propulsion systems	74
10.4 New aerodynamic opportunities	77
Prandtl Plane Concept	79
11. Energy consumption and green house gas emissions.....	79
11.1 Energy consumption and emissions of hybrid electric aircraft.....	81
11.2 Reduced emissions.....	82
12. Economics	83
12.1 Acquisition cost.....	83
12.2 Aircraft life	83
12.3 Maintenance cost	83
12.4 Battery cost.....	84
12.5 Energy cost.....	84
13. Electric aircraft design for Norwegian requirements	85
13.1 Short field operations	86
13.2 Electric aircraft and noise.....	87
13.3 Aircraft size	88
13.4 Cost related to introduction.....	88
13.5 Requirements for infrastructure.....	89
Electricity	89
Other infrastructure	90
13.6 First implementation of electric aircraft in Norway.....	90
13.7 Daily operation and charging.....	91
14. Route Stavanger – Bergen.....	92
15. Timeline.....	94
16. Risk	96
17. Further work	96

1. INTRODUCTION

The history of transportation has proceeded as a series of disruptive breakthroughs. From the invention of the wheel to the harnessing of animal power and the wind millennia ago, and from the steam of the industrial age to the development of the internal combustion engine barely a century ago, humanity's means for getting from place to place have changed dramatically. The latest of these disruptions appears to be upon us in the form of widespread electrification. Although the innovation of electric vehicles actually goes back to the 1830s, the necessary economic, societal, and technological conditions for their robust adoption have only now been met.

Fundamentally, the current, deeply established travel paradigm based on fossil fuels is unsustainable. It is unsustainable both with regard to the consuming of limited resources, as well as the emitting of climate-altering gases into the atmosphere from the burning of these resources. The problems of dwindling fuel supply paired with rising emissions are exacerbated by soaring rates of individual car ownership, especially in rapidly developing, high-population countries including China and India, additionally contributing to societal hardships such as congestion in urban areas.

In addressing the myriad issues posed by fossil fuel use, the electrification of road traffic is on an upward trend. In a few countries, electric vehicles have now arguably reached the tipping point where their adoption will accelerate organically without regulatory measures from politicians. Generally low fossil fuel prices in recent years (and more recently amplified by the ongoing COVID-19 situation) have forestalled some of the progress towards electrification in other countries, but the outlook remains very positive. More than a dozen major car manufacturers worldwide are now selling substantial stocks of hybrid and all-electric vehicles, up from the handful at the turn of the millennium that struggled for market share.

At the core of this revolution is battery development, strengthened by a growing market and the motivation for designing ever-better batteries. In parallel, sustainable, renewable energy production has taken hold in many countries, with an alignment of strategic government policies and commercial interests working to all but guarantee the continuing rapid expansion of generation capacity and utilization.

In this overall picture, the electrification of air travel emerges as a consequence of the international consensus to target reductions in fossil fuel consumption in aviation.

There will continue to be arguments that electrification is not solving sustainability and emissions problems because some production of electricity is through the burning of fossil fuels, including the most pollution-generating source, coal. Yet as energy production steadily shifts toward renewable sources, the advantages of electrification will likewise be further realized.

In Norway at least, this argument against electrification for aviation does not hold, because 98% of the country's electricity generation is from renewable hydropower. Furthermore, the Norwegian distribution network is fairly well-developed, and through proper planning, the distribution of energy to power both road transport and aviation is not considered a challenge.

The particularities of the Norwegian air travel market, and more broadly Scandinavia, also align with the prospect of more efficient aviation with reduced emissions. According to Avinor, the average Norwegian citizen embarks on one return domestic flight per year, and one return international flight per year. This has remained largely unchanged since 2012, with foreign citizens representing most of the traffic growth. Other means of transport besides flying become prohibitively costly and time-consuming because of the relatively long distances between settled areas in Scandinavia and the often-uncompromising topography, including fjords, mountains, and seas.

Alongside the latest disruption in human transportation that electrification poses, another revolution is looming: autonomy. Driverless vehicles are already beginning to enter service in select areas. The widespread rollout of this

technology for road travel—anticipated next decade—will promote newly efficient personal transport with significant reductions in accidents.

Thanks to electrification, along with advances in aeronautics and aerodynamics hastened by the rise of unmanned aerial vehicles, also known as drones, the future of air travel should be in store for a similarly sweeping leap forward. The vast majority of air travel today flows through a tiny fraction of the available airfields, concentrated in hub airports usually near major metropolitan centres. This hub-and-spoke model makes air travel attractive only for trips of several hundred kilometres or more, with local and regional trips instead taken by road, further adding to vehicle use, congestion, and emissions. A new fleet of economical-to-run, electrified aircraft could make regional and even local air travel feasible, especially if employing short- or vertical take-offs. Unlike the air travel the world has known for decades, the air travel of this near-future could be personalized, independent, and on-demand. Indeed, transportation by wheel, by wing, and by blade are all poised for truly disruptive change, so long as governments, societies, and individuals are willing to seize the moment.

The influence of the COVID-19 pandemic on these trends has yet to be fully borne out, but so far it has had dramatic consequences for all activities related to the travel industry and air transportation in particular. The situation is draining available resources from the major players in the aviation industry, meaning activities towards future technology may be delayed and not be as prioritized as previously planned.

That being said, there are so far no indications that the long-term, main direction towards electrification of air travel, and in particularly regional transport, has been changed by the pandemic. The electrification of road transport has likewise not shown any signs of slowing down, and it may even be suggested that the desire and determination to advance electrification has grown during the last six months.

2. SCOPE

Green Future AS, assigned by Avinor for the original report from 2018 and by Start Norge AS for this updated 2020 report, has made this study with the aim of giving greater insight into the future possibilities of electric aviation in general and the opportunities for Norway in particular. This information may provide background for making informed decisions that will ensure that Norway can plan and develop infrastructure to incorporate future electric aviation as part of a sustainable transport sector that is cost-, energy-, and emissions-efficient.

The intent of the study is to point out possible opportunities not only related to meeting infrastructure requirements, but also to enable involvement in technology development that ensures new electric aircraft are suitable to operate in Norway.

Additionally, this 2020 report offers a more detailed look at the possible electrification of the 180 km route between Bergen and Stavanger, the second and fourth largest cities in Norway.

3. METHODOLOGY

This study is based on information from public sources including white papers, research papers, books, news media articles, journal perspective articles, interviews with companies and stakeholders, and more. During the work with the 2018 and 2020 studies we have had a dialogue with Siemens, Rolls-Royce, Bauhaus Luftfahrt, Heart Aerospace, Airbus, Ampaire, Zunum, Pipistrel, Eviation, and others.

A range of companies is included to exemplify activities and products, but it should be noted that there may be other companies equally skilled or with better products that may not be mentioned. This study has not evaluated the quality of the different projects and future technologies presented. There are also a number of developmental projects that are not sharing information about their status.

4. GOVERNMENT POLICIES

Government policy has historically had a major impact on the transportation's sector movement towards wider electrification. In the years ahead, government initiatives will likewise weigh heavily on the aviation industry as it moves toward electrification.

A key historical example involving ground vehicles is the California Zero Emission Vehicle (ZEV) rule, adopted in 1990. In a 2008 study, researchers at the Institute of Transportation Studies at the University of California, Davis described ZEV as "arguably one of the most daring and controversial air quality policies ever adopted," adding that "some consider it a policy failure, while others credit it with launching a revolution in clean automotive technology." The mandate required all car manufacturers to have a zero-emission vehicle available for sale in California which, as a highly populous state with some 30 million residents at the time (around 40 million today), has significant auto market clout. The mandate was heavily fought by the automotive and oil industries. Despite the debate, nearly all car manufacturers accordingly bolstered their relevant R&D programs and unveiled prototypes of electric vehicles. Today, 30 years later, electric vehicles are poised to become the only kind of vehicle in some of the world's major countries. China, the U.K. and France are just a few of the nations preparing to phase out petrol cars in the future. Overall, there is a strong tailwind for electrification of road transport.

The aviation sector is likewise under governmental pressure to reduce emissions significantly. In Norway, for example, policymakers have called for all short-haul flights to be electric by 2040. It is understood that aviation cannot shift entirely to electricity, but there is a clear expectation that this may be possible for regional flights and certainly for General Aviation and Light Aircraft. The Scandinavian nation is also one of 88 countries to have signed up to the United Nation's International Civil Aviation Organization's voluntary programme of carbon-neutral air travel growth, called Carbon Offsetting Scheme for International Aviation (CORSIA), which will begin on January 1, 2021. CORSIA is a global market-based measure to keep international aviation-related carbon dioxide emissions at 2020 levels through the obtaining of carbon offset units through the worldwide carbon market.

Avinor, which owns and operates 45 airports in Norway, has also taken a proactive role in the efforts to curb the growing carbon emissions of the aviation industry, having looked since 2007 into sustainable aviation fuels (SAF) through a number of initiatives. In January 2016, Avinor's Oslo Airport became the first hub in the world to offer sustainable jet biofuel to all airlines refuelling there. The project was extended to Bergen airport in 2017.

Within the European Union (EU), the EU Commission expects that the aviation industry will deliver technology solutions that leverage sustainable energy supplies to mitigate impacts on the climate. A 2011 report from the Commission¹ proposes key goals for aviation as a whole to attain in the first half of the 21st century. These goals include, to quote from the report, by "2050, technologies and procedures available [should] allow a 75% reduction in CO₂ emissions per passenger kilometre and a 90% reduction in NO_x emissions. The perceived noise emission of flying aircraft is reduced by 65%. These are relative to the capabilities of typical new aircraft in 2000." A 2017 EU Commission report² further lays out a specific target for small commercial electric aircraft with up to 30 seats and medium ranges of up to 200 km to be operational by 2035.

In the United States, the change in government in the 2016 election has slowed much of the forward trajectory with regard to initiatives that might promote electric aviation. During the previous Obama Administration, which

¹ Kallas, S., and M. Geoghegan-Quinn. "Flightpath 2050: Europe's Vision for Aviation: Report of the High Level Group on Aviation Research." (2011);

<https://ec.europa.eu/transport/sites/transport/files/modes/air/doc/flightpath2050.pdf>

² European Commission Directorate General for Research and Innovation. "Electrification of the Transport System, Studies and Report." (2017); ec.europa.eu/newsroom/horizon2020/document.cfm?doc_id=46372 [pdf]

embraced the global consensus on climate change science, the agency responsible for air transport, the Federal Aviation Administration (FAA), set an aspirational goal in 2012 (reiterated in 2015) of "achieving carbon-neutral growth for U.S. commercial aviation by 2020, using 2005 emissions as a baseline."

This goal was to have been pursued through energy efficiency improvements in engines and airframes enabled by public-private sector partnerships. The chief initiative in this regard is the Continuous Lower Energy, Emissions and Noise (CLEEN) Program, announced in 2010 and succeeded by the CLEEN II Program in 2015, intended to run through 2020. In the programs, the FAA has partnered with industry in cost-sharing to accelerate research and development, primarily into alternative fuels and cleaner-burning combustion engines. None of the technologies or projects explicitly identified for funding involve hybrid or pure-electric aircraft propulsion, and funding remains uncertain.

Furthermore, the current Trump Administration is questioning whether to uphold commitments made under the previous Obama Administration to participate in the initial phase of CORSIA. Government-funded efforts toward electrifying aviation have continued in the U.S. are through its space agency, NASA, which will be covered later in this study. At the time of this study's publication in October 2020, the U.S. presidential election is a month away, with potentially significant ramifications for the country's aviation and related energy and climate change policies.

So far, China has not made any explicit or substantial national policy with regard to electric aviation. A four-seater electric aircraft, the RX4E, took its maiden flight in October 2018. A two-seater electric aircraft, the RX1E, received its certification from the Civil Aviation Administration of China (CAAC) in 2018. Given China's increasingly prominent efforts in addressing environmental issues and climate concerns, however, there is indeed reason to believe that the world's most populous country will soon align with the EU and to an extent the U.S. in striving toward cleaner aviation, or even setting more aggressive targets.

5. ELECTRIC AIRCRAFT – HOW DO THEY WORK

The term "electric aircraft" can refer to both pure-electric aircraft and hybrid electric aircraft, the latter of which incorporates a second energy source in the form of a conventional fossil fuel, biofuel, or hydrogen.

A pure electric aircraft is powered by a battery or another source of electric power. In such an aircraft, electric motors may replace today's turbine engines, as well as turboprop and turbofan engines. An electric motor can be designed and dimensioned to drive a fan engine for high-speed, large aircraft such as the Airbus 350 or the Boeing 787, or to power propellers on a medium range, smaller aircraft like the Bombardier Dash 8. An electric motor is well-suited for air transport because it offers high efficiency in all practical sizes over a wide range of revolutions-per-minute, along with superior reliability.



The Pipistrel Velis electric aircraft by the Slovenia-based company Pipistrel. The Velis is the first standard-type certified electric powered aeroplane approved for pilot training in Day VFR operations, having received certification in July 2020. The Velis is in serial production. (Credit: Pipistrel)



Charging a Pipistrel Velis aircraft. (Credit: Pipistrel)

A hybrid electric aircraft is powered via a combination of electricity from batteries or another electric energy storage source and an internal combustion engine. Various configurations for these aircraft exist, with two major configurations known as serial and parallel. A serial hybrid can use only electric motors for propulsion but relies on a combustion engine coupled to a generator to produce extra electricity as needed. A parallel hybrid directly uses an electric motor and a combustion engine for propulsion.

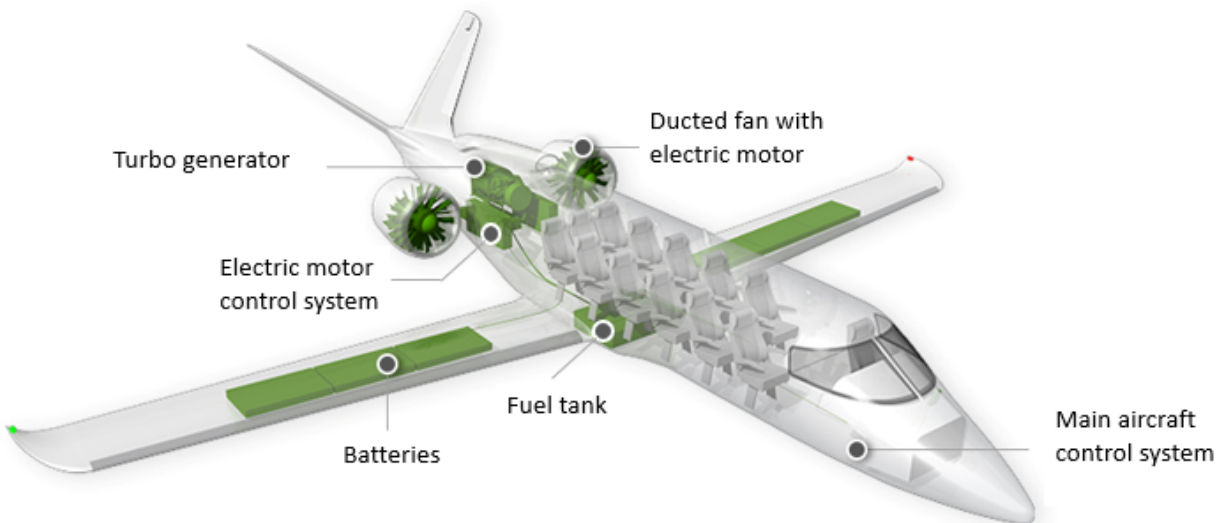

Zunum Aero, a company based in the United States, is designing serial hybrid electric aircraft with fossil fuel-powered range extenders. (Credit: Zunum Aero)

The appeal of the hybrid approach reflects the intrinsic limitation of electric aircraft at this point in their technological development, which is the capacity and weight of the batteries necessary for longer flights. By the year 2025, however, a battery energy density of around 500 Wh/kg is widely anticipated, approximately twice that which is readily available today. With batteries of this energy density, an aircraft may be able to carry enough "juice" to cover distances of approximately 500 km, not taking into account the energy reserves required for emergency situations where the aircraft cannot land at the intended airport and must divert to another.

5.1 WHY ELECTRIC?

Electric motors, first invented in the 1830s, are a highly efficient way to convert electric energy to rotational power. A combustion engine produces motion based on controlled explosions or burning fuel in a turbine. This combustion generates more heat than motion, wasting a significant portion of the potentially available energy. In contrast, the electric motor experiences only a small loss from electric resistance when creating an electric field. Overall, the efficiency of an electric drive train may be higher than 90% from battery to shaft, while a turboprop engine normally falls in the range of 20 to 25% for short, 30-minute flights; for longer flights at higher altitude, the turboprop may reach 35% efficiency. A turbofan engine can offer higher efficiency, but still not in the regime attainable via electric drive trains.

Without mechanical contact between parts and the absence of the high temperatures needed for burning fuel, electric engines suffer little wear-and-tear, thus requiring far less maintenance than conventional combustion engines. For aircraft with very high utilization rates and intended long service lives, this reliability becomes a huge advantage. It should be emphasized that maintenance in an electric system will be predictive rather than event-based. The electric systems can "self-check" their health over time much more readily than a traditional engine aircraft and thus know in advance when performance is degrading to the point where maintenance will be required. Engine maintenance may be reduced in the range of more than 50% and unplanned repairs reduced equally compared to conventional aircraft, thus vastly reducing costly aircraft out-of-service time.

Compared to combustion engines, electric engines are also more reactive and easier to control. The motor is controlled by digital signals and reacts within milliseconds. Additionally, electric motors are scalable and maintain the same efficiency regardless of whether they are small or large motors. This combination of reactivity and scalability makes electric propulsion systems ideal for distributed propulsion systems described later in the study.

Although the engines used in electric aircraft would be "new," they are just manifestations of tried-and-true technologies, whose underlying physics and engineering are extremely well-understood.

6. CERTIFICATION

The challenges in developing an electric aircraft are not only technical, but also a complex matter of regulations and rules for aircraft design and operations. The rapid developments of batteries and drive systems for road vehicles are in many ways the enablers for electric aviation, though automotive systems do not have to fulfil redundancy and other requirements that will be set for aviation.

The requirements to obtain the desired level of safety are formed by standards and regulations, and these have yet to be defined for electric aviation. The regulatory authorities must work hand-in-hand with the aviation industry in establishing a path for matching technology development with new regulations.

The initial airworthiness certification for electric powered aircraft will pose certain challenges, given the novel sorts of components and architectures involved compared to conventional, fossil-fuel powered aircraft. On the other hand, continuous airworthiness certification, which takes into account maintenance and other factors, can be expected to hew more closely to the regime for conventional aircraft.

The applicable certification requirements for electric aircraft depend on the aircraft maximum take-off mass and maximum number of passengers. Certification Standard 23 (CS23) applies to aircraft up to a take-off mass of 8 618 kg and 19 passengers, also known as the Commuter category, and Certification Standard 25 (CS25) applies to larger aircraft that exceed these criteria. The CS23 and CS25 standards have similar structures, however CS25 has a stricter regime with more certification requirements and a closer scrutiny by the relevant competent authority. Those authorities will be, for example, the European Aviation Safety Agency (EASA) in Europe and the Federal Aviation Administration (FAA) in the U.S.

An important task to be performed early on in an electric powered aircraft project will be to assess the certification basis. This is so design engineers will know which requirements their part of the design shall comply with, as well as to set parameters moving forward on the levels of innovation that could pass muster. Most of the CS23 or CS25 requirements will be inherently applicable to an electric powered aircraft, for instance in flight characteristics, structure, systems, and documentation. There are, however, currently no specific requirements for electric aircraft propulsion and storage and transmission of significant amounts of electrical energy. The appropriate requirements will either have to be adapted from corresponding fossil fuel aircraft requirements or written anew in certain cases.

Broadly, the electric powered aircraft certification basis will consist of:

- a) Existing certification requirements which will apply unchanged; and
- b) Existing certification requirements which will be adapted to electric propulsion; and
- c) New certification requirements for electrical propulsion ("Special Conditions," "Certification Review Items"); and
- d) Unique certification requirements for the specific project.

A part of the certification basis work will be to establish the Means of Compliance for each requirement, which stipulates if compliance shall be shown by analysis, calculations, simulations, ground test, flight tests, et cetera, or combinations of these means.

7. BATTERY STATUS

Energy storage technology is an enabler of the transition from an unsustainable paradigm based on fossil fuel consumption to a sustainable energy ecosystem based on consumption from renewable sources.

In order to shift the transportation sector to electricity, there is a dire need for energy storage solutions with high energy densities. Vehicles such as cars and airplanes cannot be directly connected to a constant energy source via the grid, as for instance rail lines can. Furthermore, cars and airplanes both have size and mass constraints, which requires all the energy for their operation to fit within a relatively small volume. Today, batteries look to be the best-suited technology, but considerable research and development resources are also being invested in alternative technologies including fuel cells and supercapacitors.

Electric cars will be the main driver of battery development and adoption for the transportation sector. This battery development will not, however, occur in bespoke isolation. A major, parallel driver for advances in battery storage technology is renewable energy production from solar and wind sources, which in order to increase their reliability and market penetrance must pack away some of their generated energy for when the Sun does not shine and the wind does not blow. Per these two sectors' considerable energy storage appetites, the battery industry will grow rapidly in the years ahead.

Over the past 25 years, scientists have successfully improved battery performance by modifying or replacing materials to create more efficient chemistries and form factors. The cost per unit of stored energy has plummeted by an order of magnitude over this single generational period.

Increased performance and dramatically lower cost have brought electric cars to the point where they can travel more than 500 km on a single charge. Grid storage for renewable energy is poised to become competitive. Nor is there any end in sight, for battery efficiencies continue to improve and are outpacing many observers' predictions.

7.1 BATTERY PRODUCERS

The high levels of activity and jockeying within the battery technology development sector, along with the push to establish robust production capacity, is often dubbed the “battery battle.” Although investment is surging, it of course remains a limiting factor. Given the number of competing teams and companies in this burgeoning sector, available information may be influenced by differing agendas as well as legitimately differing organizational views. Politicians and governments are naturally involved as well, seeking to ensure that as an increasingly strategic sector, battery development and production are located in their region or country. An additional key aspect to the enterprise of batteries is secured access to raw materials.

The world’s capacity to make battery cells has expanded rapidly in recent years. Today, manufacturing operations globally can produce around 320 gigawatt-hours (GWh) of batteries per year for use in electric cars. This is well above the approximately 100 GWh of batteries required for the 2.1 million electric cars that were sold in 2019.



An artistic impression of Northvolt's first factory to be established in northern Sweden. (Credit: Northvolt)

As for where global production capacity is located, China has today the lion's share with more than 70% of the world's production capacity, followed by United States, Europe, South Korea, and Japan. This balance is expected to shift somewhat, but China is likely to increase capacity rapidly and is expected to maintain 50% of the world's production capacity by 2030.

Based on the global auto industry’s stated targets for electric vehicle production, the current battery manufacturing capacity will need to more than triple to around 1,000 GWh by 2025. (This is assuming that the COVID-19 pandemic does not significantly scramble the outlook by forcing the temporary shuttering of battery production hubs, as has occurred in China's Hubei, Hunan and Guangdong provinces, or the ability and desire for the auto industry to still meet its targets.)

Global annual battery production is anticipated by the World Economic Forum to grow annually by 25% and reach a production capacity of 2,600 GWh by 2030³.

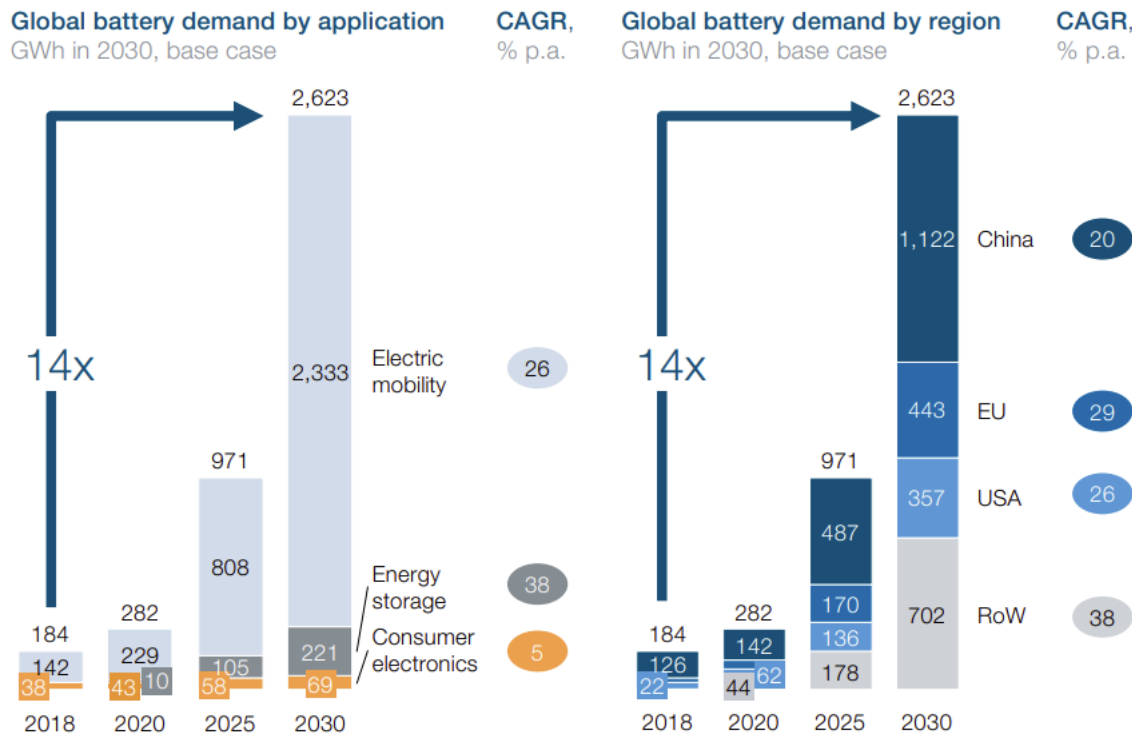

Credit: World Economic Forum, Global Battery Alliance; McKinsey analysis

Companies including CATL, LG Chem, BYD, Northvolt, Panasonic, and others are working hard to plan and finance new factory constructions in different regions to reach this volume by 2030⁴. An important factor in establishing new plants is energy efficiency and low- or zero-carbon footprint production processes. This may benefit Norwegian and Nordic initiatives for battery production with access to clean hydropower.

³ World Economic Forum, M. analysis. 2019. A Vision for a Sustainable Battery Value Chain in 2030 Unlocking the Full Potential to Power Sustainable Development and Climate Change Mitigation. http://www3.weforum.org/docs/WEF_A_Vision_for_a_Sustainable_Battery_Value_Chain_in_2030_Report.pdf

⁴ Kristina Edström, Battery 2030+ Roadmap, March 2020. https://battery2030.eu/digitalAssets/861/c_861008-l_1-k_roadmap-27-march.pdf

Top 5 Lithium ion Battery Producers by Capacity

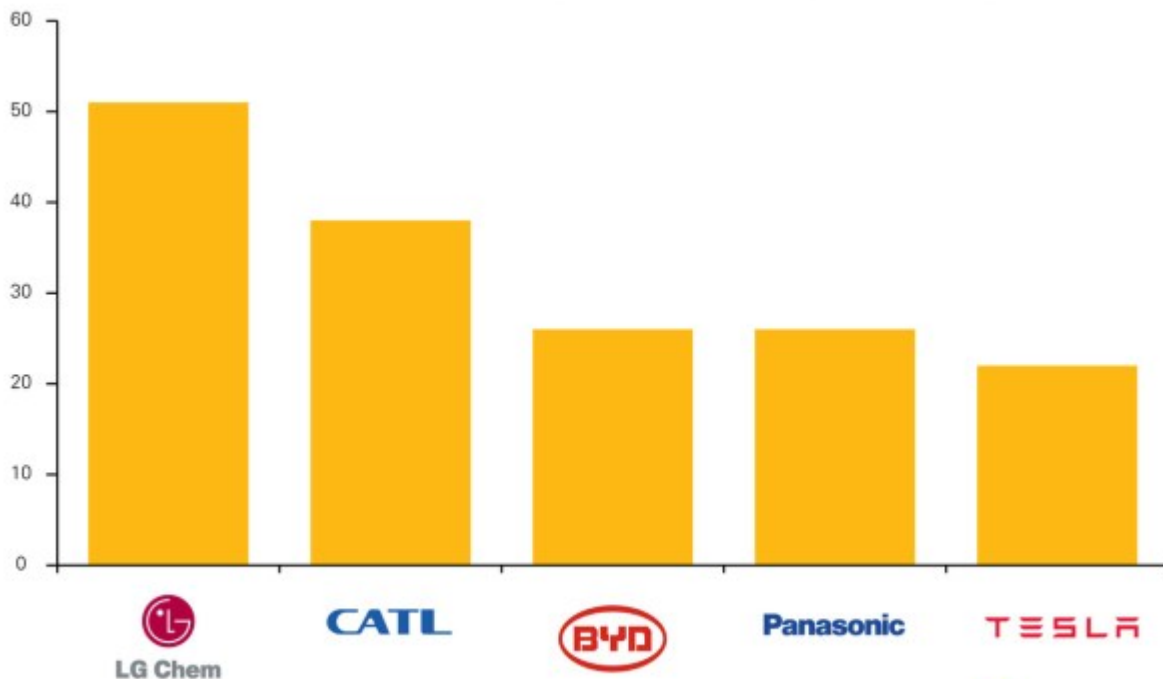

Source: Benchmark Mineral Intelligence

Production capacity in 2019 expressed in GWh. (Credit: Benchmark Mineral Intelligence)



In the following portion of this report are profiles of some of these and other top battery manufacturers.

LG CHEM

LG Chem entered the electric vehicle battery business in 2009. The company has supplied batteries to global carmakers such as Audi and Nissan. It currently operates battery plants in China, the U.S., and its home country of South Korea. In 2017, the company invested in a factory in Poland initially planned to annually produce up to 100 000 electric vehicle batteries, and shortly thereafter announced plans to extend capacity to 300 000 batteries. LG Chem has been expanding its lithium ion cell capacity rapidly in the last two years and is establishing five mega-factories on three continents.

CATL - CONTEMPORARY AMPEREX TECHNOLOGY LTD.

CATL is a rapidly growing Chinese company supported by the Chinese government that is aiming to be a global leader in supplying the automotive industry with batteries. The company plans to raise 13.1 billion yuan (\$2 billion) to finance construction of a battery cell plant nearly the size of Tesla's Gigafactory in Nevada. CATL already sells the most batteries to the biggest electric vehicle makers in China, and its lithium-ion batteries will go inside locally made electric vehicles from major automakers Volkswagen, BMW, and Hyundai. Toyota, Honda, and Nissan are also considering CATL batteries for planned China-made vehicles. Domestic companies using the batteries include BAIC Motor Corp., the biggest EV seller in China, and Zhengzhou Yutong Group Co., the world's biggest maker of buses. CATL is expanding by establishing offices in Europe and the U.S. The company has acquired 22% of Finland's Valmet Automotive Oy, a contract manufacturer for Daimler's Mercedes-Benz and supplier to Porsche and Volkswagen's Lamborghini. CATL's lithium ion battery production capacity is approximately 40 GWh a year. One of

the major challenges for CATL is to produce at the same quality as the battery industry's tier one suppliers Panasonic, Samsung SDI, and LG Chem

BYD

Based in Shenzhen, BYD—which stands for “Build Your Dream”—is a Hong Kong-listed, Chinese car company that produces about 500 000 cars and buses per year, with the share of electric vehicles or plug-in hybrids in these totals having grown from 100 000 in 2016 to approximately 225 000 in 2018. Consistent with BYD's strategy of vertical integration, it is China's largest battery maker, having opened a 24 GWh battery factory in 2018 and then broke ground in 2019 on another 20 GWh factory. The company is strongly supported by the Chinese government in ensuring the transition to zero emissions vehicles in the transport sector.

SAMSUNG SDI

Also based in South Korea, Samsung is best known as an electronics manufacturer. The company has a dedicated renewable energy storage arm, Samsung SDI, that is developing future electric vehicle batteries. The company has previously announced battery cells with energy densities high enough to propel electric vehicles as far as 600 kilometres after a just 20-minute charge. SDI is additionally conducting research into solid-state batteries, a technology that offers improved capacity and safety compared to traditional lithium-ion cells. Internationally, Samsung SDI established a plant in Hungary in 2018 with a production goal of 50 000 EV batteries.

PANASONIC

Panasonic is the world's biggest supplier of lithium-ion batteries for cars with production facilities in Japan, China, and the U.S. The company continues to invest in additional capacity at all three facilities. Panasonic makes battery cells for Tesla's Model S and Model X, as well as the company's latest offering, the Model 3, at Tesla's Gigafactory 1 in Nevada. The facility is also manufacturing batteries for Tesla's stationary energy storage products. At the Gigafactory 1 alone, Panasonic had aimed in 2018 for a record 35 GWh of battery cell capacity with plans for significant increases, though as of 2020, that full capacity has not yet been met. Furthering its work in electric vehicles, Panasonic has previously announced a plan with Toyota to collaborate in developing solid state batteries, building on a joint venture the companies have shared for over two decades.

NORTHVOLT

Northvolt is a European initiative to establish battery competence and production for supplying the European car industry. Equity capital has been raised to enable the establishment of Europe's first homegrown gigafactory for lithium-ion battery cells in Skellefteå, Sweden. The factory is to be powered by 100 percent clean energy. Large-scale manufacturing will commence in 2021 with annual capacity ramping up to at least 32 GWh by 2024, with the potential to expand to 40 GWh in the future. In addition to the gigafactory in Sweden, Volkswagen and Northvolt plan to set up a 50/50 joint venture to establish a 16 GWh battery cell factory with an intended location in Salzgitter, Lower Saxony, Germany. Volkswagen is investing around \$1 billion (€900 million) in joint battery activities with Northvolt. This effort will enable Europe to compete in the coming wave of electrification, while aiming to develop and produce battery cells with the lowest CO₂ footprint possible.

Compared to 600 GWh globally, Europe's battery demand is projected to reach 200 GWh by 2025, a market worth an estimated €250 billion annually, according to European Commission Vice-President Maroš Šefčovič. Although European carmakers assemble battery packs for electric cars, with the essential building blocks coming mostly from Asia, the continent has no significant player in battery cells, recognition of which is spurring the Northvolt initiative. The Commission has accordingly branded batteries as "a key enabler" in its flagship project to establish an Energy Union, saying that battery development and production play a strategic role in the modernisation of Europe's industry.

7.2 NORWEGIAN BATTERY ACTIVITIES

Norway may be well suited for battery manufacturing with availability of renewable energy, space, good logistics and availability of some key materials.

This may favour Norway and attract car manufacturers in Europe and investors to establish battery manufacturing in a political stable region.

Battery activities in Norway;

FREYR

A Norwegian company started in 2018, Freyr is planning to build a combined 32+2 GWh lithium ion battery facility and 600 MW onshore wind farm in two municipalities in mid-Norway.

The company's primary market will be European electric vehicles. Other markets for Freyr products will include short-haul aviation, as well as marine, stationary storage, and offshore segments. The company is pursuing research and development initiatives by partnering with leading Norwegian and European institutions and companies.

MORROW BATTERIES

A new company, Morrow was founded in 2020 by Agder Energi Venture and Gjelsten Holding.

The company is planning to establish a new battery factory in southern Norway. The factory will benefit from raw materials such as nickel and cobalt mined by Glencore Nikkelverk in the same region and be powered by Norwegian renewable energy. In this way, the company aims for the factory to be "greenest" of its kind in the world. Aligning with this vision is the intended recycling of used batteries in order to keep the raw materials in the value chain.

Morrow has announced that it will first establish a pilot manufacturing line and an R&D centre by 2023 and a giga factory, with a capacity of 32 GWh, will start battery cell manufacturing by the end of 2024.

BEYONDER

Located in the Stavanger region, Beyonder plans to turn Norwegian sawdust into carbon and sand into silicon for use as the cathodes and anodes in battery cells, rather than relying on conventional heavy metals. The batteries will be able to top charge in minutes, have high power, and be able to withstand 100 000 charging cycles. The batteries will be suitable for buses and ferries with fixed routes, because their capacity will be limited, but the charging time will be so short, the company says, that the battery can be efficiently filled at the bus terminals and ferry docks. A Beyonder factory expected to be completed by the end of 2023, with capacity of up to 5 000 000 cells annually.

GRAPHENE BATTERIES

The company is developing lithium batteries that will use sulfur as the cathode and feature a dendrite-free lithium anode, all packed in porous carbon. Graphene Batteries is playing a central role in the creation of the aforementioned company, Morrow Batteries.

SIEMENS

The German-based multinational conglomerate opened a battery factory in Trondheim in 2019, producing battery packs for the maritime market. The primary market is electric ferries, but fishing boats, working boats, the aquaculture industry, and offshore interests are all intended as part of the customer base. Siemens' ambition is to produce battery modules equivalent to 300-400 MWh, which, for example, will be able to supply 150-200 ferries.

CORVUS ENERGY

Canadian-owned Corvus Energy opened a battery factory in Bergen last year, also producing battery packs and targeting the maritime market. With so many customers and partners in Norway, it made sense to have a battery factory locally, Corvus believed. Capacity is 400 MWh per year.

HYDRO VOLT

Formed out of a cooperation between Hydro, an aluminum company 35 000 employees in 40 countries, and Swedish Northvolt, Hydro Volt is joint venture planning on a battery recycling hub in Fredrikstad, with an expected production start in 2021. Investment is estimated at NOK 100 million. The largely automated hub will process over 8 000 tons of batteries annually to start, with expanded capacity envisioned.

ELKEM

Norway-based Elkem is the world's leading provider of silicones and silicon solutions. The company recently announced plans to establish a battery factory in Porsgrunn in southern Norway. The batteries will probably have graphite anodes that are suitable for consumer electronics, cars, and energy storage. A pilot factory is slated to go into operation early next year in Kristiansand.

7.2 BATTERY DEVELOPMENT

The trajectory of battery development over the next decade or more will largely be determined by the automotive industry because the majority of batteries produced will be intended to meet the increasing demand for electric vehicles. While it is expected that that next generation batteries will be solid-state, the massive and increasing investment in battery research and development makes it difficult to predict the next-next generation's energy density. A conservative expectation is that energy density will maintain its recent historical rate of gain, which is at least 8% per year.

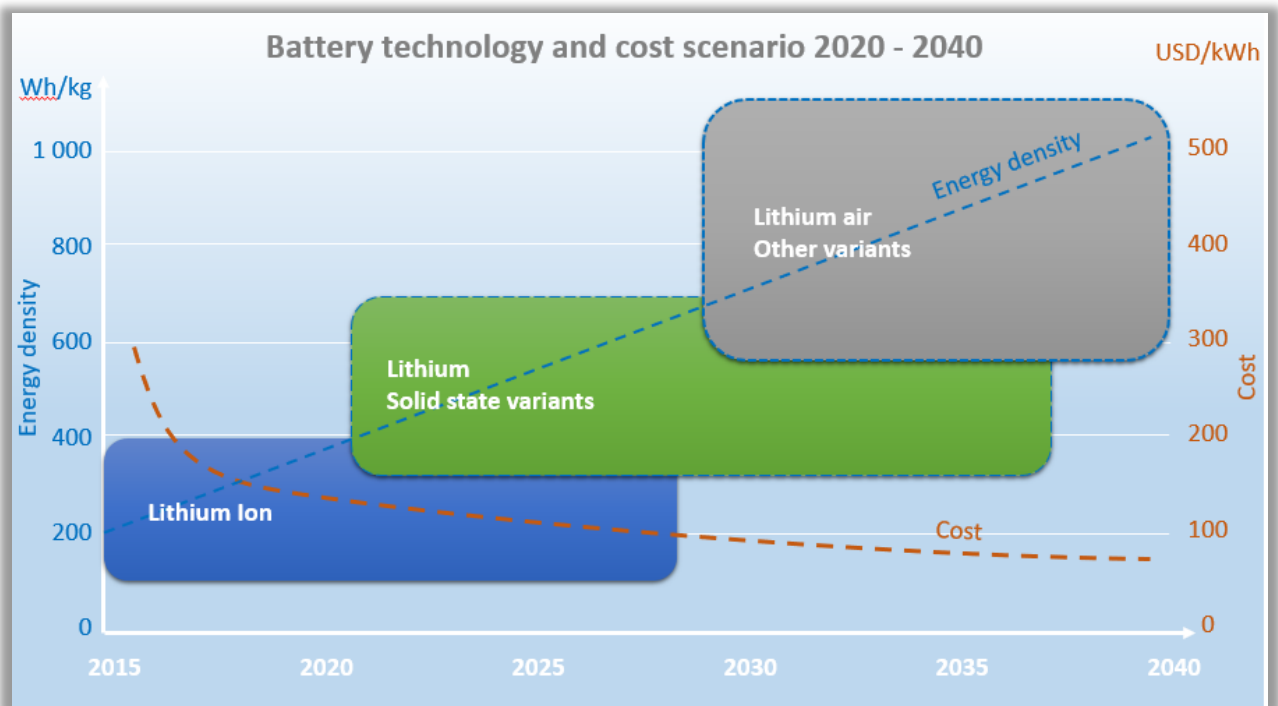

A simplified illustration of battery chemistry and a scenario for battery development. (Credit: Green Future AS)

There is some common ground between the requirements and ideal enabling thresholds for car batteries and aircraft batteries, but there are also differences. The parameters may be set up in a matrix as follows:

	Cars	Aircraft
Lifetime	Typically 6 years and 200 000 km, which is less than 1 000 cycles. Requirements for commercial road transport and all-day autonomous driving may change this figure	A commercial regional aircraft may fly more than 10 hours every day. Will aim for at least 5 000 cycles
Safety	Important	More important than on the ground, given that failure in mid-air would be catastrophic. Safer battery chemistries, while more expensive up front, could save costs on battery enclosure and ventilation for extra safety from less stable chemistries and designs
Cost	Very important. The car industry will propel low-cost solutions	The ideal battery for commercial aircraft will serve a longer duty. Costs for aircraft batteries are directly related to lifetime and may accept significantly higher initial costs if lifetimes are longer
Second use	The automotive industry is already prepared for extensive second use. Preferably, the initial design of battery modules fits directly into applications for second use without any modifications	Likely to be similar opportunities for aircraft batteries

The following sections will now provide further details about certain critical battery properties.

7.3 FAST CHARGING

Batteries may be charged at the same rate as they are capable of discharging. The lithium-ion batteries preferred for most automotive applications today can deliver power 5 times the capacity, for a so-called C rating of 5C. These batteries can be charged with the same high power, 5C, given sufficient thermal management. Until the battery reaches an 80% or 90% full state of charge, the internal battery resistance is low and the battery temperature can be controlled. During the last charging 10% to 20% of topping up, however, the battery loss increases and more heat is released, during which time the charging power is reduced.

The automotive industry is targeting fast charging as high as 10C, which means down to 5 minutes for charging up to an 80% to 90% state of charge. Because a car rarely is completely empty of charge when charging starts, the goal of charging to at least near-full in under 5 minutes should clearly be within reach. Next-generation batteries with these sorts of power and charging capacity may be well-suited for electric/hybrid aircraft.

In terms of chemistry, lithium sulphur batteries are considered a possible next-generation battery, offering higher energy density but they may be less capable in power discharge and fast charging. As mentioned prior, solid state lithium batteries are another promising battery type.

7.4 THERMAL CONTROL

Internal temperature is an important parameter for batteries, impacting the rate of charging, capacity, and lifetime. Ideal temperatures may (as an example) be between 15 and 30 degrees Celsius; if the temperature can be maintained within those limits, then batteries should perform according to their maximal design specifications. Operations of batteries outside their prescribed limits will negatively influence performance.

Obviously, temperature management is extremely important for ensuring an optimal and finely tuned battery system for aircraft propulsion. During discharge and charging, there will be a certain efficiency loss (resistance) internally in the battery, creating heat that needs to be controlled. In addition, the ambient environmental temperature may heat or cool the battery. For an aircraft, the cooling demand will be during fast charging and high-power output during the take-off and climb phases. During descent and low-power output during high-altitude cruise, there will be a demand to conserve the heat in order to prevent the temperature from falling to suboptimal levels.

It is expected that battery systems for commercial aircraft propulsion purposes will be liquid-cooled. This method is not only well-proven and efficient, it also can maintain a reasonably even temperature throughout all the cells in the battery module. Air-cooling is challenging because it is less efficient than liquid cooling and difficult to maintain the airflow in such a manner that allows for even cooling.

That said, the availability of cold air at high altitudes may be a huge advantage for the thermal management of aircraft batteries, given the ability to cool to the optimal temperature during cruise and descent and in preparation for subsequent fast charging once on the ground. During fast charging at the airport, the aircraft battery cooling system may also receive additional ground grid power for efficient cooling in preparation for take-off in warm climates. These additional energy needs should be relatively minimal, given that during climb the outside air temperature will gradually grow colder to provide efficient cooling as required.

7.5 BATTERY SWAPPING SYSTEMS

An alternative solution to fast charging is battery swapping at the airport. As its name implies, it involves simply replacing mostly depleted battery modules with freshly charged modules. This approach is also under consideration in earnest for electric vehicles where fast charging is not fast enough, so to speak, and quickly getting a vehicle back on the road with a fully topped battery is a high priority.

7.6 BATTERY LIFETIME

Batteries for aircraft propulsion will rely on the highest possible energy densities because weight is a critical factor. The battery also must deliver a certain amount of power at different states of charge. Battery lifetime will be defined by a certain reduction in capacity, reduction in available power, or a combination of the two.

For automotive use, end-of-life is typically defined as a 75% to 80% reduction in capacity; reduction in available power is not regarded as a critical such parameter for most car utilization situations. For an aircraft battery, end-of-life may also be defined at a certain reduction in ability to deliver power to the propulsion because this power may be critical for safety during take-off.

An additional key point regarding battery lifetime is the concept of second use, in which a battery first serves an automotive (or aviation) application, then is reused in a secondary application for grid storage, for instance. This approach extracts significantly more value out of a singly manufactured battery, ultimately cutting down on lifetime and thus upfront costs. Accordingly, battery modules for aircraft will likely be designed to serve both first and second use applications.

7.7 LIMITED SUPPLY OF RAW MATERIALS FOR BATTERY PRODUCTION

The increasing production of electric vehicles, coupled with expected growth in the use of grid-connected battery systems for storing electricity from renewable sources, has made the adequate supplying of raw materials a looming issue for lithium-ion batteries, the dominant type of rechargeable product on the market. Lithium batteries rely on a host of materials, including of course lithium, but also nickel, cobalt, and graphite. Some electric motors additionally require so-called rare-earth elements.

For the near future, no absolute limitations are anticipated on battery manufacture due to shortages of the critical metals. But according to an analysis published in the journal *Joule* in late 2017 that evaluates the next 15 years, temporary slowdowns in production could arise from short-term bottlenecks in the supplies of some key metals, especially lithium and cobalt.⁵ In the latter's case, it is not poor availability of the metal, but political and economic precariousness that threaten its supply. More than half of the world's cobalt is mined in the Democratic Republic of the Congo, a nation with a long history of armed conflict and corruption. Flaring tensions there around the time of the study contributed to the price of the bluish grey metal going up more than 190% over a period of 18 months. Given the favourable forecasts for electric vehicle uptake and continued government initiatives to move past fossil-fuelled engines, carmakers and battery producers are rapidly locking in supply agreements with mining companies.⁶

There have been a number of other analyses on this subject up through 2020, but the conclusion has remained the same. Overall, ample material for mass adoption of batteries for electric cars, as well as aircraft, is out there; it is only a question of mining capacity to ensure supply.

⁵ Olivetti, Elsa A., Gerbrand Ceder, Gabrielle G. Gaustad, and Xinkai Fu. "Lithium-ion battery supply chain considerations: analysis of potential bottlenecks in critical metals." *Joule* 1, no. 2 (2017): 229-243.

⁶ Sanderson, Henry. "Electric vehicle ambitions spark race for raw materials." *Financial Times*, October 24, 2017.

8. ALTERNATIVES TO BATTERIES

Batteries are currently the preferred energy storage standard for electric aircraft propulsion as well as electric cars. Fuel cell technology is the closest alternative to batteries and has been used in space applications for many years. A fuel cell converts fuel directly to electricity without any emissions but requires fuel to be brought with it. Liquid hydrogen is the most likely fuel source, having four times the energy content of kerosene jet fuel. A tremendous amount of research and development is going into this technology and it is debated if this technology may replace batteries in the future. So far, fuel cells can provide an on-board energy conversion efficiency of 50%, with the potential to improve further. Still, there remain additional challenges such as energy-efficient production of hydrogen, along with infrastructure for transport, storage, and on-board tanks for liquid hydrogen, which must be kept at minus 250 Celsius.



The German research institute DLR has equipped this flying test platform with a 45-kW hydrogen fuel cell combined with a 22-kWh battery. The aircraft can cruise at 145 km/h and has a range of 750 – 1 500 km. (Credit: DLR)

9. INDUSTRY ACTIVITY AND PROJECTS

While electric propulsion represents a radical change from today's propulsion technologies, the technologies behind it are not radically new. As mentioned previously, the electric motor dates back to the 1830s, and in 1884, the battery-powered airship *La France* made its maiden flight.

Since then, many electrically powered aircraft have been built, but all as prototypes for demonstration or light aircraft. With battery storage capacities and weight now becoming high and low enough, respectively, per a given volume for commercial aviation consideration, the only debated uncertainty in the aviation industry is the timeline for when the advantages from electrification can be implemented for the different aircraft and engine categories. In the commercial aircraft manufacturer sector, there are a handful of projects for regional aircraft, though it is possible there are other projects that have not been publicly announced. The aviation supplier industry is also participating in electrification and is spending considerable resources to position itself for the future supplying of the manufacturer sector. Again, for some of the projects there will be public information available, but not for others.

Beyond the increasing interest from the existing aviation industry, there are also other industries and financial investors highly intrigued by electric propulsion. In a new segment of urban air transport or "air taxis," more than 70 projects are underway. As one would expect, a high number of projects have also started in the light aircraft segment. Finally, there are many universities and research organisations that are involved in doing studies on many aspects of electrification.

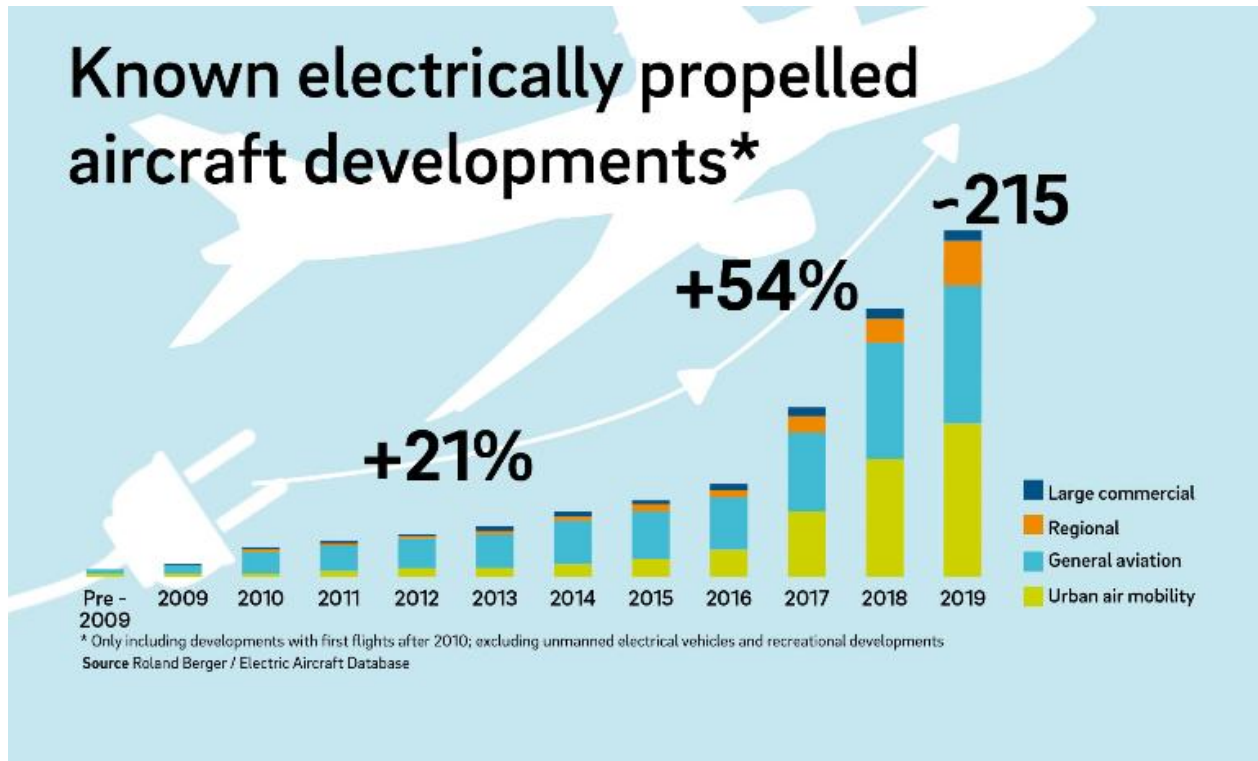

According to the global consultancy Roland Berger, electric aviation projects have increased rapidly since 2016. (Credit: Roland Berger)

This section of the study will now offer an overview of the main activities within different aviation segments, including large aircraft, regional aircraft, light aircraft, and urban air transport.

9.1 COMMERCIAL AIRCRAFT

Developing, certifying, and producing large commercial aircraft will require a very competent organisation with experienced personnel and substantial financial resources. A production organization and facility will further be required. Because the investment in an aircraft fleet is a long-term commitment, customers will need a reliable supplier.

These basic arguments point in the direction of existing aircraft manufacturers playing a primary role in the electrification of commercial air transport, and large aircraft in particular. Although those arguments are pointing in the direction of established companies, disruptive technological breakthroughs can also present great opportunities for newcomers such as Tesla, which has been a bellwether in the automotive industry's shift to electric cars.

As important as the aircraft manufacturer is, it will be critical that component suppliers participate in the development. The collaborative project announced a few years ago by Airbus, Rolls Royce, and Siemens is the ideal model to drive electrification. Recently, Rolls Royce has been taking over the Siemens department for advanced electric motor and driveline technology and is continuing to develop electric propulsion systems for aviation. Other major propulsion manufacturers like Safran, General Electric, and others are also working on electrification projects.

Of further note, ATR, Bombardier, and other significant manufacturers of regional turboprop aircraft have not pursued the same level of developmental progress over the last 20 years as they have for the larger aircraft in their fleet families. Because the majority of the aircraft in this regional segment are due for replacement over the next 15 years, a technology shift to more efficient aircraft with low-noise electric propulsion may be a great opportunity for manufacturers in this segment.

The COVID 19 situation has dramatically changed the ability for the major aircraft industry and key suppliers to invest in future R&D projects. Accordingly, the information in this chapter could be subject to sudden change, due to shifting priorities at the various companies.

BOEING

We will begin with Boeing, which identifies itself as "the world's largest aerospace company and leading manufacturer of commercial jetliners, defence, space and security systems." The company website offers the following high-level profile of the firm: "With corporate offices in Chicago, Boeing employs more than 153,000 people across the United States and in more than 65 countries . . . Today, the company manufactures the 737, 747, 767, 777 and 787 families of airplanes and the Boeing Business Jet range. New product development efforts include the Boeing 787-10 Dreamliner, the 737 MAX, and the 777X. More than 10,000 Boeing-built commercial jetliners are in service worldwide, which is almost half the world fleet. The company also offers the most complete family of freighters, and about 90 percent of the world's cargo is carried onboard Boeing planes."

The company has numerous efforts underway that are addressing the electrification of aviation. One example is Boeing HorizonX, a venture capital wing with a mission to "unlock the next generation of game-changing ideas, products, and markets." In practice, this means allocating capital to assist in technology commercialization and market access for new startups developing "revolutionary concepts . . . to get their ideas off the ground," as Boeing HorizonX says on its website.

Boeing NeXt was an initiative intended to participate in introduction of next-generation air vehicles in urban, regional, and global markets. This initiative was discontinued in July 2020.

Related to electrification, an ongoing project with an origin as far back as 2006, is the Sugar Volt. The Sugar (Subsonic Ultra Green Aircraft Research) project began as a brainstorm about futuristic, environmentally friendly aircraft design. The Sugar Volt concept has since become based on a hybrid electric propulsion drive system with a number of innovative new technologies to reduce drag and energy consumption. The project aims for a reduction in fuel burn of more than 70% and radically lower noise. The new technologies are targeted for commercial aviation in the timeframe of 2030 – 2040, though the company has not yet decided if, or when, any of the new technologies will be incorporated into Boeing aircraft.

The Boeing company Aurora Flight Science is addressing future aircraft designs and autonomous flights. This company is addressing development and manufacturing of advanced unmanned systems and aerospace vehicles.



From Aurora Flight Sciences, the PAV (Passenger Air Vehicle). (Credit: Aurora Flight Science)

A new company, called Wisk, was established in 2019 as a joint venture between The Boeing Company and Kitty Hawk Corporation with the ambitious aim of shaping the future of mobility.



Concept of aircraft being developed by Boeing and the Kitty Hawk Corporation. (Credit: Wisk)

As a corporation, Boeing has been significantly impacted by the COVID-19 pandemic and by the ongoing grounding of the 737 Max airliner following two fatal accidents. It is expected that handling those major challenges has top priority and may slow down activities related to future projects.

AIRBUS

Airbus is the European equivalent to Boeing, producing large commercial aircraft. The Airbus Group has approximately 130 000 employees. At its website, the company describes itself as producing "highly successful families of aircraft, ranging from 100 to more than 850 seats." These aircraft include the single-aisle A320 Family, including the A320neo; the widebody, long-range A330 Family; the next-generation widebody A350 XWB Family; and the double-deck A380. Airbus also produces military aircraft, rotorcraft, and space equipment.

The company is ambitiously working on a variety of projects in the electrification space, ranging from unmanned delivery drones and air taxi concepts to full-size passenger aircraft. Expressing its interest and intentions in electric propulsion, Airbus has included the following statement on its website (though this statement has been removed as of 2020): "Electric and hybrid-electric propulsion is the most promising technology to develop means of transportation with improved environmental performance that are less reliant on fossil fuels and use energy more efficiently. That's why Airbus is investing heavily in research dedicated to developing all necessary technologies, and partnering with the best to make it a reality."

One of the Airbus projects was founded in May 2015 and is called A³ ("A-cubed"). It is the advanced projects outpost of the company in Silicon Valley. A³ focuses on projects centred around three traits: speed, transparency, and a commitment to culminating in producible demonstrators at convincing scale. One of the projects is the VTOL Vahana described in this study. The Vahana programme was completed in 2019. The second eVTOL demonstrator

in the Airbus portfolio, City Airbus, is continuing its flight test campaign throughout 2020 to be able to bring fresh insight to the concept development table.

The E-fan X was another activity meant to demonstrate electric 2 MW turbine propulsion that launched in 2018 but was discontinued in early 2020.



A concept for a hydrogen-powered zero emission plane, unveiled in September 2020. (Credit: Airbus)

In September 2020, Airbus unveiled new concepts for a zero-emission commercial aircraft powered by hydrogen rather than jet fuel. The company envisions this sort of aircraft being ready to carry passengers by 2035.



The AirbusZEROe turboprop concept, which would use liquid hydrogen fuel. (Credit: Airbus)

Hydrogen can be combusted through modified gas-turbine engines or converted into electrical power that complements the gas turbine via fuel cells. The combination of both creates a highly efficient hybrid-electric propulsion chain powered entirely by hydrogen.

The concept is based on a different idea for how to achieve zero-emission flights and uses different aerodynamic configurations for what the company says is its ambition of "decarbonising the entire aviation industry."

ATR

Owned by Airbus Group and the Italian company Leonardo, ATR manufactures two sizes of turboprop aircraft, the 70-seat ATR 72 and the 50-seat ATR 42. The company makes approximately 80 aircraft a year, has produced an approximate total of 1 400 aircraft, employs 1 300 people and sees about \$1 800 million in annual revenue. ATR's only business is turboprops and it utilizes a high amount (approximately 20%) of composite materials in its products.



An image of the ATR 72. (Credit: ATR)

ATR and its partners are participating in the Clean Sky Project, which describes itself as the "largest European research programme developing innovative, cutting-edge technology aimed at reducing CO₂, gas emissions and noise levels produced by aircraft. Funded by the EU's Horizon 2020 programme, Clean Sky contributes to strengthening European aero-industry collaboration, global leadership and competitiveness."

The ATR 42 may be a suitable platform to convert to hybrid electric propulsion, and some concept work has been pursued. There are no known plans for electrification of propulsion at ATR today, but this may change as more hybrid electric propulsion systems for this class of aircraft become available.

BOMBARDIER

Bombardier, a Canadian company, describes itself as "a global leader in the transportation industry, creating innovative and game-changing planes and trains." The firm has nearly 60 000 employees. Bombardier manufactures business aircraft in the Learjet, Challenger, and Global aircraft families, as well as commercial aircraft, such as the C Series, CRJ Series, and Q Series.

The C Series is a newly developed, single-aisle aircraft specifically designed to accommodate 100 to 150 seats. Financial challenges in Bombardier have troubled the program and led to a joint venture agreement with Airbus for manufacturing the C-series. The CRJ Series family is a popular regional jet designed for 60 to 100 seats, with more than 1 900 having been ordered worldwide. The Q400 is a turboprop designed for up to 90 seats with a cruise speed of 360 knots. It is the latest model in the former Dash 8 series, which has sold a total of 1 200 aircraft with more than half that number representing the Q400 model.

Of note, the Widerøe fleet of 42 turboprop aircraft is drawn from this Bombardier family, from the Dash 8-100 to the latest Q400. The latter is an excellent candidate for hybrid electric propulsion. As with ATR, this possibility is likely to be explored when hybrid electric propulsion systems become more mature.

EMBRAER

Embraer is a Brazilian company with 18 000 employees that has produced more than 8 000 aircraft in different segments. Today the company is producing 200 commercial jets per year but is no longer making turboprops. The relatively new E-Jet family is designed for 70 to 130 seats and the ERJ family is designed for 37 to 50 seats. Embraer also produces a broad range of business jets, military aircraft, and small planes for agricultural use. (Of note, Widerøe has purchased two E-Jets from Embraer.)

The company has pursued some intriguing partnerships. In December 2017, Embraer confirmed that the company was engaged in discussions with Boeing regarding a partnership. The terms of partnership agreement was confirmed in 2019 but terminated again by Boeing in April 2020 probably caused by the COVID 19 situation. Back in April 2017, Embraer announced an agreement with the ride sharing, food delivery, and transportation network company Uber to explore the concept of small electric vertical take-off and landing vehicles (VTOLs) for short urban commutes. Paulo Cesar de Souza e Silva, Embraer's CEO, said the following in a press release at the time: "We firmly believe we need to explore several new business concepts that may impact air transportation in the future. This is a unique opportunity to complement the air transport knowledge of a visionary and revolutionary ground transport company. On exercising this partnership, we will be developing new technologies, new products and new business models which could generate opportunities for Embraer in the future."



Embraer design for flying SUV (Credit: Embraer)

The Uber collaboration, which plausibly involves electric aviation platforms, is the lone such announcement to date, but Embraer certainly has the competence and capability and is likely to enter the electrification arena soon.

Despite the COVID 19 challenges Embraer continues developing an battery-powered and all-electric air taxi concept vehicle with an 8-rotor configuration to take off and land vertically, plus a set of pusher propellers for fixed wing forward flight. Embraer has also issued a white paper “Flight Plan 2030” describing an air traffic management for urban air mobility.

TEXTRON GROUP

Textron Inc. is a U.S.-based multi-industry company, with brands such as Bell Helicopter, Cessna, Beechcraft, E-Z-GO, and Jacobsen. The \$14.2 billion company employs 35 000 people and has a presence in more than 25 countries.

The Beechcraft, Cessna, and Hawker brands account for more than half of all General Aviation flying. On its website, the company says it "has a broad range of products including Citation business jets, Beechcraft King Air and Cessna Caravan turboprops, Beechcraft and Cessna piston engine aircraft and the T-6 military trainer aircraft."

Bell Helicopter, one of the largest manufacturers of commercial and military vertical take-off vehicles in the U.S., announced in 2017 its partnership with other aircraft manufacturers to collaborate with Uber in creating an on-demand network of electric VTOL aircraft. In public comments at the Las Vegas Consumer Electronics Show (CES) show in January 2018, Bell Helicopter President and CEO Mitch Snyder said: “Bell Helicopter is innovating at the limits of vertical flight and challenging the traditional notion of aviation to solve real-world problems. The future of urban air taxi is closer than many people realize. We believe in the positive impact our design will have on addressing transportation concerns in cities worldwide.” At the CES 2019 show, Bell unveiled a design for the Bell Nexus, a hybrid-electric VTOL air taxi.

Textron Group is known for innovative new solutions, so its shareholders will probably expect the company to continue looking ahead and taking steps toward electrification.



The Bell Nexus air taxi concept. (Credit: Bell Helicopter)

9.2 REGIONAL AIRCRAFT PROJECTS

Aircraft in the category 6 – 19 seats is likely to enter the market first and maybe as early as mid-2020. This category is aimed towards general aviation like private owners, air taxi/charter companies and commercial flights for point-to-point regional travel.

Overview - regional aircraft projects						
Make/ project	No of passengers	Landing field	Top speed	No of engines	Propulsion Power	Hybrid
Zunum Aero	12	2 200 ft	550 km/h	2	1 000 kW	Hybrid
Eviation	9	3 000 ft	440 km/h	3	900 kW	All Electric
Ampair - Twin Otter	19	2 200 ft	325 km/h	4	1100 kW (Est.)	Hybrid
Pipistrel Unifyer 19	19	TBD	TBD	TBD	TBD	TBD
Aura-Aero	19	2 200 ft	400 km/h	TBD	1 200 kW	TBD
Heart Aero	19	2 200 ft	400 km/h	4	1600 kW	TBD
Daher	9	TBD	TBD	TBD	TBD	TBD
Electra Aero	TBD	STOL	TBD	TBD	TBD	TBD
VoltAero Cassio 600	10	1800 ft	200 kts	1 - 3	600	Hybrid

ZUNUM AERO

Founded in 2013, Zunum Aero is headquartered in Seattle and positioned itself as "the Tesla of the aviation industry." Zunum has expressed that its mission is to establish electric aviation as the primary mode of fast short-haul transit, lighting up tens of thousands of airports offering air service with door-to-door times and costs 2 to 4 times better than today.

Zunum's ultimate goal is to enable point-to-point air service to tens of thousands of secondary airports and feeders to hubs, offering high-speed transit to communities everywhere, while placing short-haul on a path to zero emissions by 2040, eliminating 50% of all commercial aviation emissions. The company offered this quote: "A quick drive to a nearby airport where you can walk onto quiet, electric aircraft much as you would board a bus today, for a fast flight to an airport closer than ever to your destination — all while leaving neighbours undisturbed and the planet healthy."

Zunum is maturing hybrid electric technologies via a rapid prototyping cycle, progressing from a full-scale ground prototype of the power system that has already been tested, to a flying testbed and then flying prototype in the early 2020s. Zunum is also developing key components, such as MW-class lightweight motors and power converters, low-pressure quiet fans, thermal systems, wing-integrated battery packs. The company has also been a leading producer of regulation for electric aircraft as founding member of the FAA/ASTM Electric Aircraft Working group since 2013.

Financial challenges forced Zunum to suspend most of its development activities in 2019. This suspension occurred when the company was on the threshold of flight testing its prototype 1 MW powertrain, including a purpose-designed electric machine, power electronics, and electric propulsors. Zunum is in the process of recapitalizing with new investors, and has received continuing support from customers, partners, and key employees through a very challenging period.

Zunum expects to resume forward motion at the end of 2020 towards 12- and 50-seater aircraft. The prototype powertrain supports both platforms (2 machines on the 12-seater, 6 on the 50-seater). The company has revised their plan of record to prioritize a hydrogen fuel cell hybrid over the turbogenerator hybrid. This study had previously staged those technologies in reverse order, given the lower readiness and acceptance of hydrogen-based technologies, but that circumstance has changed given the urgency to "Build Back Better" following the pandemic.

Zunum has a close partnership with Safran and is in continuous discussion with several of the engine majors on collaboration around critical elements of the powertrain, such as the range-extending turbo generator. Zunum is

also engaged in market development and legislative efforts across the U.S., EU, and Asia, and will soon be announcing a launch customer.



The envisioned Zunum Aero family of aircraft. (Credit: Zunum Aero)

The following table offers data on the proposed Zunum aircraft:

Data	Zunum ZA10	Zunum ZA50
Seat capacity	12	48 – 60
Maximum propulsion power (MW)	1.0	4.5 – 5.2
Cruise speed (km/h)	500	700
Energy consumption battery power (kWh / seat / km)	0.12	0.10
Maximum take-off weight (kg)	5 136	22 000 – 27 000
Maximum battery pack weight (kg)	688	3,470
Maximum fuel weight (kg)	590	2,050
Electric / Hybrid Range, Battery 500 Wh/kg (km)	175 / 1 160	250 / 1 300
Electric / Hybrid Range, Battery 900 Wh/kg (km)	330 / 1 350	450 / 1 600

Energy Assumptions: 92% total efficiency from battery to propeller shaft, 30% efficiency for generation, dominated by the gas turbine.

EVIAION

Eviation, an Israeli start-up, has an ambitious project utilizing benefits with new light composites, new aircraft design, and all-electric propulsion. The team behind the project is highly experienced, both from leading a number

of successful venture companies and product development efforts related to composites and advanced power electronics.

Eviation describes its 9-passenger aircraft, named Alice, as using "distributed propulsion with one main pusher propeller at the tail and two pusher propellers at the wingtips to reduce drag, create redundancy, improve efficiency, allow for augmented stability and turbulence mitigation." A fully composite structure with optimal aerodynamic design is envisioned. Alice is intended to have a total weight of 6 350 kg with a 900-kWh battery.

In early 2019, Eviation secured \$200 million of investment to cover certification and production while the first prototype was assembled in Vannes in northwest France. In April 2019, Eviation selected the MagniX Magni 250s 375 shp (280 kW) electric motor turning at 1,900 rpm as an alternative power option to Rolls-Royce 260 kW motors.

At the 2019 June Paris Air Show, a full-size static Alice was exhibited. The first airline customer was also announced, namely the Hyannis, Massachusetts-based Cape Air. The company ordered 92 aircraft, priced at \$4 million each.

The Singapore-based MagniX investor Clermont Group took a 70% stake in Eviation aircraft in August 2019. By October 2019, over 150 Alice aircraft had been ordered by two American companies.

A setback occurred on 22 January 2020, when a fire broke out, apparently in a ground-based battery system, with the end result being that the prototype was destroyed.

On 18 May 2020, GKN Aerospace announced a partnership with Eviation on the design and manufacture of the wing, empennage, and electrical wiring interconnection system of subsequent Alice airframes.

Down the road, the company is planning to max the FAR 23 category (19 PAX) based on the Alice platform with more or less the same design, just bigger. A preliminary design has been completed. Additionally, a FAR 25 version is planned to carry a larger number of passengers (like today's ATRs and up). The design will be different from Alice for the FAR 25 variant.

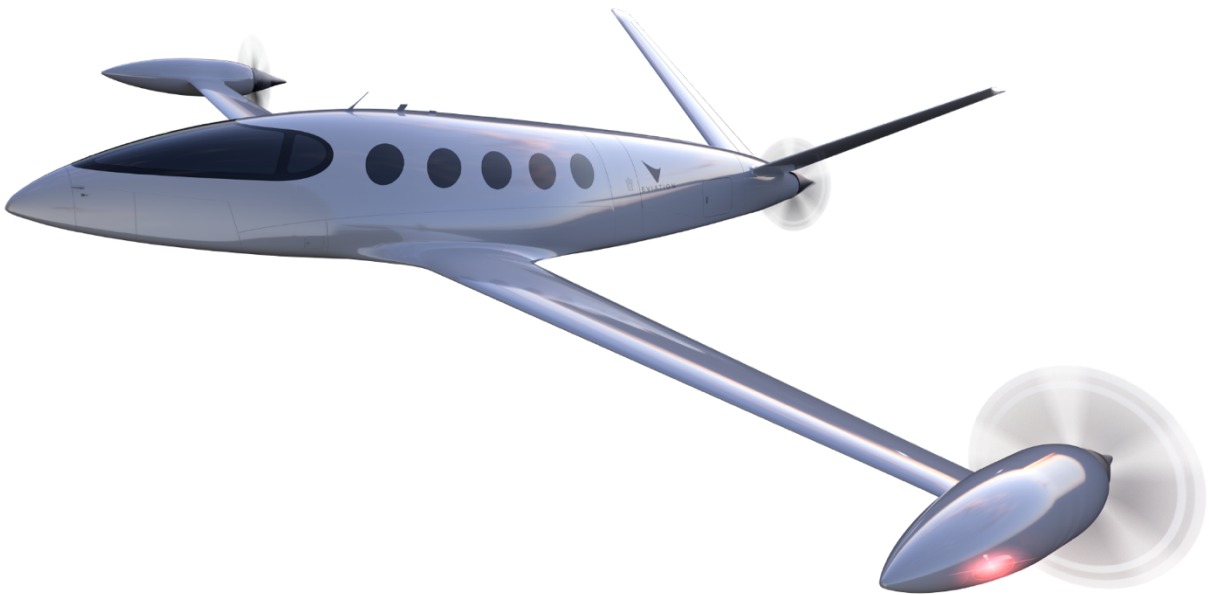

The concept of the Alice 9-seater. (Credit: Eviaton)

AMPAIRE

Ampaire is an innovative, Los Angeles-based aircraft company that was founded with 9 employees in 2016. The company is working on a project featuring all-electric propulsion with a unique and advanced design, taking advantage of the latest aerodynamic inventions. The company has a strong engineering team with recent experience from world-leading, advanced aviation projects.

Ampaire aims to fly a crewed demonstrator aircraft, with the goal of using the aircraft in experimental pilot demonstration programs. Ampaire's ultimate goal is to have a 9 passenger retrofit aircraft using a propulsion system certified with an STC (Supplemental Type Certificate), with a 19-passenger retrofit to follow. Both aircraft retrofit programs will leverage Ampaire partner companies.

Projects being pursued by Ampaire included the TailWind, which is based on a ground-up design powered by an all-electric propulsion system and "configured inside a sleek lightweight package tailored to maximize efficiency," as the company says on its website. A variant is the TailWind-H, a hybrid electric version of the aircraft, designed for longer-range flights.



The Tailwind concept. (Credit: Ampaire)

Another project is the Eco Otter SX, a 1 MW aircraft designed as a low-emission variant of the workhorse DHC-6 Twin Otter turboprop, which is used worldwide as a regional airliner, cargo hauler, and bush plane, as well as in a variety of specialized operations from surveillance to parachute jumping.



The Eco Otter SX concept, which is a modified DHC-6 Twin Otter. (Credit: Ampaire)

Finally, another project is the Electric EEL, which is primarily a testbed aircraft for the development of high-powered electronics, inverters, motors, and related systems. It is a platform for developing scalable technology and certification processes. The EEL can also serve owner-flown, charter, and short-haul regional airline/cargo carriers. It is based on the Cessna 337 Skymaster aircraft.



The Electric EEL, a modified Cessna 337. (Credit: Ampaire)

PIPISTREL

Pipistrel, a major small aircraft designer and manufacturer based in Slovenia, specializes in energy-efficient and affordable sport aircraft. The company manufactures the Alpha Electro, the first fully electric aircraft in serial production, and more recently developed the Velis Electro, the first pure electric aircraft in the world to receive certification in June 2020.

The company's R&D division is working on several projects, including different aircraft designs, unmanned cargo delivery UAVs, both electric and hybrid-electric eVTOL air taxis, as well as the UNIFIER19, a hydrogen fuel cell-powered 19-seat miniliner/microfeeder. The aircraft, aimed at the intra-European transport market, is intended as an initial step toward larger regional versions. The company has completed the first stage of the UNIFIER19 project with partners Politecnico di Milano and TU Delft, developing the methodology and tools for planned multi-objective interdisciplinary design and optimization.



The Unifier19 concept by Pipistrel. (Credit: Pipistrel)

AURA-AERO

A new aircraft manufacturer formed in 2018, AURA-AERO has positioned itself as an innovative firm that is capable of evolving with the latest in aeronautical technologies. The focus of AURA-AERO's efforts is the two-seater Integral aircraft configured a distributed propeller, with 4 or 6 engines along the wing. Two versions of the aircraft is planned to address the training and aerobatic markets.

The Integral R aircraft completed a maiden flight in June 2020. AURA-AERO is now "implementing the POA Production Organisation, Design Organisation DOA, Flight Test Organization FTOM and the Type Certificate TC for the Integral R aircraft," the company reports. A production chain for Integral aircraft is under development at Toulouse Francazal airport in France.

The company also has what it calls an electric propulsion aircraft manufacturer competence centre for helping make electric aviation a reality. The company is ultimately targeting CS-23-certified aircraft, which have a 19-passenger maximum and a maximum take-off weight of 8618 kg.

HEART AEROSPACE

A Swedish company, Heart Aerospace is a spin-off from the ELISE (Electric Air Travel in Sweden) project and has garnered funding from multiple sources, including Green Deal funding from the European Innovation Council. The company is designing and building all-electric aircraft intended for regional air travel.

The aircraft under development is called the ES-19. It is a 19-seater with an operating range of 400 km. Relevant to Scandinavia, the ES-19 is being designed to handle short runways, as well as the harsh environment in Nordic countries. Initially, the ES-19 is slated to fly with two pilots, though single pilot handling is envisioned.

Development-wise, Heart has so far built and tested a full-scale electric drivetrain prototype, completed preliminary design and sizing of the ES-19 airframe, and pursued hardware-battery-in-the-loop testing for European regional air routes. The airliner in which the electric propulsion system will be integrated is an established form factor, which will significantly reduce complexity as well as the certification process to comply with EASA CS-23 regulations. Heart has also reported that it has passed the first milestones towards EASA Design Organisation Approval (DOA).

The company says it is aiming for mid-2024 for the ES-19's first flight, with deliveries starting in 2026. The company further reports that it has validated "strong market demand for our ES-19 product with LOIs from airlines across Europe, North America and the Asia-Pacific region worth approximately €2 billion."

The following table contains data on the Heart Aerospace ES-19 aircraft:

Crew	1–2 pilots
Capacity	19 passengers
Length	17 m
Wingspan	22 m
Range	400 km
Top speed	400 km/h
Charge time	20–40 min
Runway	750 m
MTOW	8600 kg
Powerplant	4 x 400kW



The ES-19 aircraft. (Credit: Heart Aerospace)

DAHER

As a family-owned company based in France, Daher's roots stretch back to 1863. Today, it is present in 13 countries and has a turnover of 1.2 billion euros in 2019. The company has three main business areas: aircraft manufacturing, aerospace equipment and systems, and logistics and supply chain services.

In the realm of electric aviation, Daher is collaborating with Airbus and Safran on a wing-mounted distributed hybrid propulsion demonstrator, named the EcoPulse™. The concept is based on Daher's TBM platform. It will feature a propulsion system supplied by Safran consisting of a "turbogenerator (a combined turbine and power generator), an electric power management system and integrated electric thrusters (or e-Propellers) including electric motors and propellers. The electric thrusters will be integrated into the EcoPulse™ wing and will provide propulsion thrust, at the same time as delivering aerodynamic gains (reducing wing surface area and wingtip marginal vortices, and therefore drag)," according to a press release.



The EcoPulse TM concept. (Credit: Daher)

ELECTRA.AERO

The company claims their mission is "to turn flygskam into Flugvergnügen," or "flight shame into flight pleasure." Electra.aero (pronounced "electra dot aero") is developing a new generation of electric short take-off and landing (eSTOL) aircraft. A start-up, the company has a veteran team with previous experience across a range of aircraft including the Daedalus human-powered aircraft, the Perseus high altitude UAV, the Orion long-endurance UAV, the XV-24 LightningStrike UAV, the D8, the PC-12, the PC-24, the Eclipse 500, the SUGAR Volt, and other projects. The company's activities are in a host of locations: Cambridge, Massachusetts; Bern, Switzerland; Washington DC; and Penrose, Colorado.

The aircraft under development is called the Electra. It is intended to use powered lift to achieve both take-offs and landings over distances that are only a few times the length of the aircraft, as short as a few hundred feet. Achieving this goal would open thousands of new locations to air service, even in urban areas, the company contends, while significantly reducing door-to-door travel times.



Concept of the Electra aircraft, intended for take-offs using only a few hundred feet of runway. (Credit: Electra.Aero)

VOLTAERO

Based in France, VoltAero is developing what the company describes as a truly unique general aviation airplane with hybrid-electric propulsion for safe, quiet, efficient, and eco-friendly flight.

The company has established a team of skilled engineers and works with several experienced industrial partners to bring in expertise in design, development, systems integration, certification, and production for a “Made in France” aircraft that benefits from the best in European technology for safe and efficient flight.

VoltAero’s proprietary Cassio design is based on an aerodynamically optimized fuselage, a forward fixed canard, and an aft-set wing with twin booms that support a high horizontal tail.

In 2022, the company plan to start production of the Cassio 330, a four-seat configuration with propulsion of 330 kilowatts. That is to followed by the Cassio 480 with six seats with 480 kilowatts, and finally the Cassio 600, with 10 seats and 600 kilowatt-propulsion. All configurations will rely on hybrid-electric propulsion.

The aim is to achieve a flight duration of at least 3.5 hours suitable for General Aviation, Envisioned users and applications include private owners, air taxi/charter companies, commercial flights for point-to-point regional travel, and other utility-category (cargo, postal delivery, Medevac) needs.

The aircraft will be certified to Europe’s EASA CS23 certification specification as a single-engine, General Aviation category aircraft, and is designed from the start for a low cost of ownership.



Concept of the Cassio hybrid-electric airplane. (Credit: VoltAero)

Cassio aircraft will be produced at a purpose-built final assembly line in the Nouvelle Aquitaine region of southwest France, with VoltAero leading a world-class team of partners and suppliers. Licensed production opportunities will be pursued in North America and Asia.

The following are some specifications for the Cassio aircraft:

Autonomy: 3.5 hours (extension possible to 5 hours)

Range: 800 miles

Cruise speed: 200 knots

Take-off/landing distance: less than 1,800 feet

Maximum take-off weight: Under 2.5 metric tons (EASA CS23 certification)

Availability: 10 hours/day (equivalent to approximately eight rotations daily)

Others

There are most likely other aircraft producers that have started or will start projects, but for whom no public information is found. Some of these makers include Antonov, Tupolev, Lockheed Martin, Mitsubishi, Comac, and Dornier.

9.3 RESEARCH PROJECTS

Although hard to put a firm number on, it is fair to say that there are hundreds of universities and research organization engaged in activities related to electric aviation. The reason for this is the excitement and enthusiasm shared among researchers and engineers for the virtually unlimited new opportunities and design freedom introduced by using electric motors. We will review a few of these efforts in the following.

BAUHAUS LUFTFAHRT

Germany-based Bauhaus Luftfahrt was founded in 2005, its website describes, "as an independent non-profit research institution in reference to the historical Bauhaus in Dessau. Since 2013, it has received institutional funding from the Free State of Bavaria, having its office at the Ludwig Bölkow Campus near Munich since 2015." Bauhaus has produced many interesting studies related to electric aviation in the last years:

CE-LINER

This concept design from Bauhaus Luftfahrt has a range of 1 667 kilometres, a cruising altitude of ten kilometres, and a cruise speed of 808 km/h. Three studied versions of the conceptualized aircraft would seat anywhere from 140 to 233 passengers. The research organization says about the idea: "The most significant novelty of the Ce-Liner lies in its all-electric propulsion system, which enables the concept to potentially exceed even the ambitious emission targets of Flightpath 2050 . . . Its two ducted fans are driven by high-temperature superconducting electric motors fed through a universally electric systems architecture (UESA) with energy from advanced lithium-ion batteries." The required energy density is estimated to be 2 000 watt-hours per kilogram, or "roughly eight to ten times as much as state-of-the-art batteries achieve today." Bauhaus Luftfahrt says the battery modules would be installed in specially adapted cargo containers.

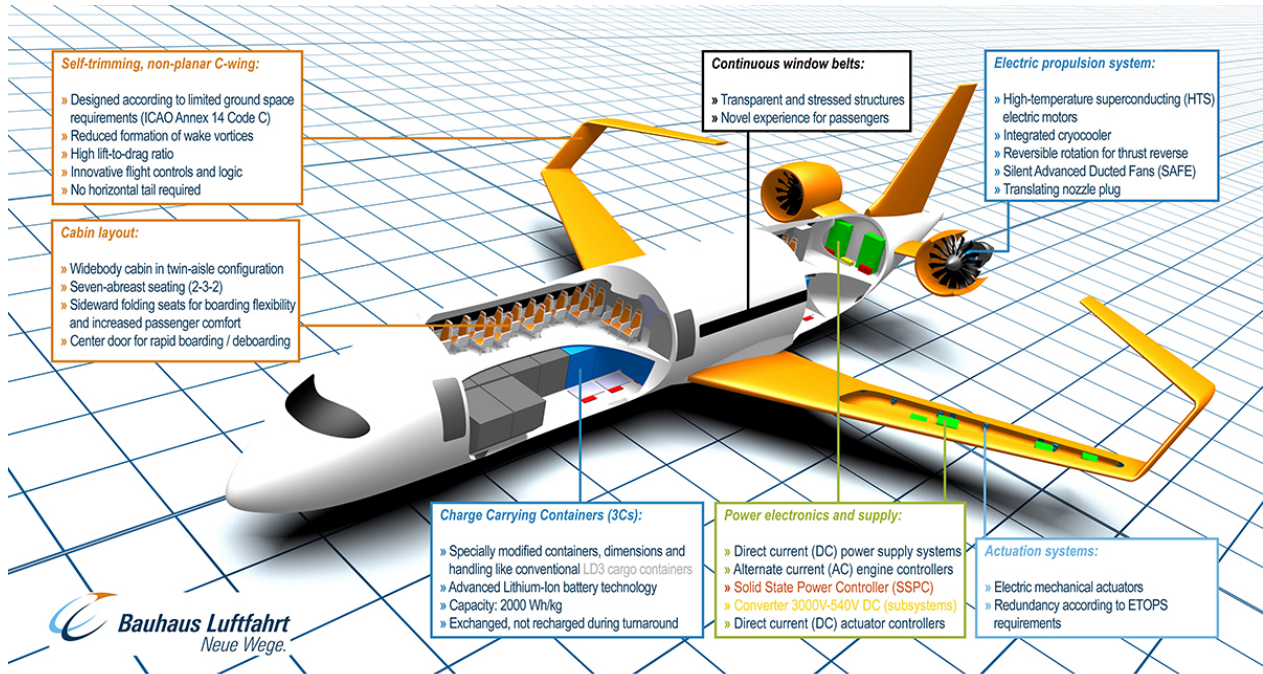

(Credit: Bauhaus Luftfahrt)

CENTAIRSTATION AIRPORT CONCEPT

Another interesting concept by Bauhaus Luftfahrt is utilization of the space above train stations for short inner-city airports connecting directly to public transport hubs. The concept makes a lot of sense in combination with new, low-noise electric aircraft concepts with STOL (Short Take Off and Landing) abilities.

The research organization describes the concept as follows: "The CentAirStation building with a length of 640 m and a width of 90 m consists of at least four levels," with each platform featuring escalators and lifts for efficient passenger transit. "The predominantly vertical passenger routes through the CentAirStation building allow very short processing times: Departing passengers will need only 15 minutes from arrival at the airport through to take-off of the aircraft. Arriving passengers will be able to exit the building just ten minutes after they got out of the aircraft in the gate position."

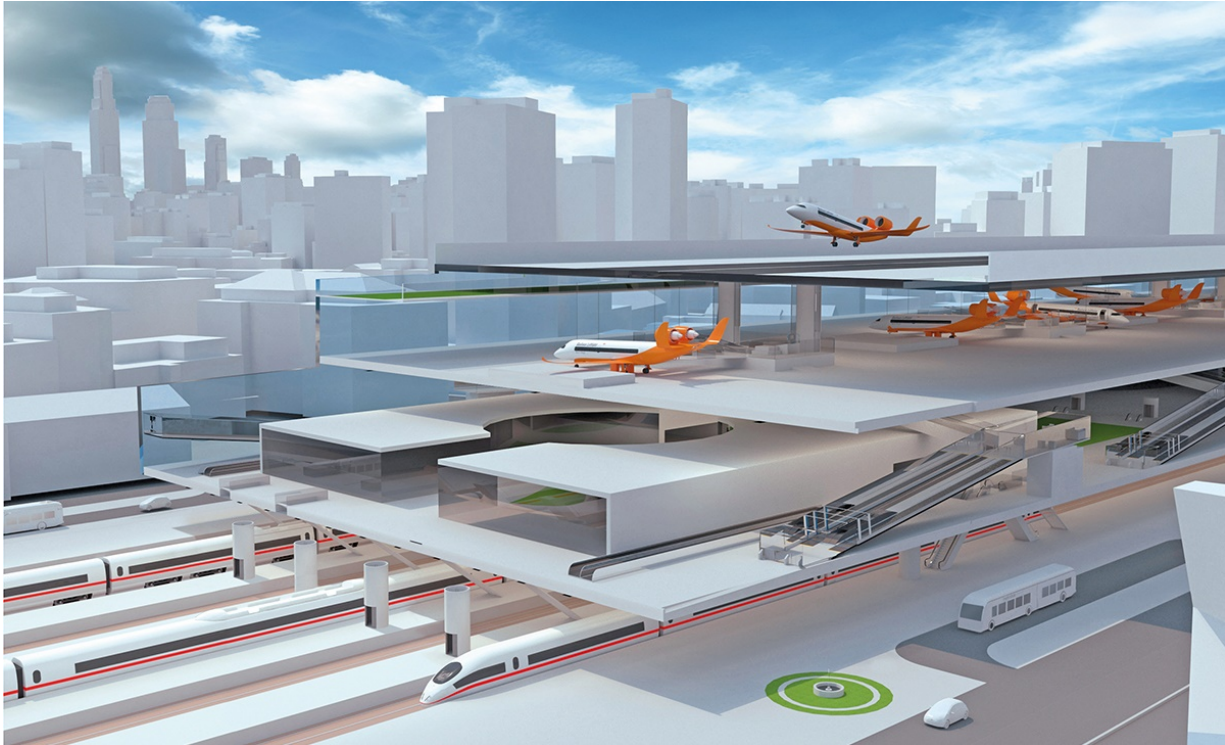

CentAirStation. (Credit: Bauhaus Luftfahrt)

CITYBIRD

CityBird, as its name implies, is an urban air transport concept. The research organization behind it says: "The CityBird has been specially designed as an aircraft for inner-city operation. The high population density in cities and the limited available space put high requirements on noise protection, safety and short take-off and landing capability (STOL) of the aircraft. Furthermore, the aircraft must be efficient and fast enough to achieve the goal of four hours door-to-door over the required range. Operation on conventional airports without affecting the running processes is provided. The long list of specifications poses major challenges for aircraft design that are addressed, among others, through the use of new technologies: a low wing configuration with aft-mounted engines, a small and faired landing gear as well as a simple high-lift system along the entire span of the wing."



CityBird concept. (Credit: Bauhaus Luftfahrt)

DLR (FEDERAL REPUBLIC OF GERMANY'S RESEARCH CENTRE)



DLR, which stands for Deutsches Zentrum für Luft- und Raumfahrt is the Federal Republic of Germany's research centre for aeronautics and space. The organization has 55 research institutes and facilities and more than 9 000 employees across the country. DLR conducts research and development activities across numerous fields, including aeronautics, space, energy, transport, security and digitalisation.

Hybrid-electric aircraft for both freight and passenger aircraft constitute one of DLR's research efforts. DLR identifies itself as "the only large-scale research institution in Europe that is in a position to study all aspects of electric flight and address the questions that are yet to be answered. To that end, DLR is conducting research into different propulsion technologies – from initial concepts and simulations all the way through to their integration into new aircraft configurations. At the same time, the researchers are investigating how this will impact the overall air transport system, looking at the expected effects for travellers, airlines and airports."

One important project is DLR's collaboration with Bauhaus Luftfahrt on the CoCoRe (Cooperation for Commuter Research) project, which is examining "the possibilities and potential for hybrid-electric 19-seater aircraft," according to the organization's website. Interestingly, "while 3000 commuter-class aircraft are in use worldwide," DLR has noted that just over a dozen "new 19-seaters have been delivered to the civilian sector annually in recent years."

As part of CoCoRe, DLR has studied how placing heavy batteries over landing gear nacelles would be a wise engineering choice, putting weight where it is needed and making it easier to swap out batteries while on the ground. DLR has also studied range-extending gas turbines for electric aircraft. The research has indicated that "56 percent of 19-seaters worldwide fly distances of less than 200 kilometres and 83 percent fly less than 350

kilometres. This usage pattern means that the combination of fully electric flight enhanced by range extenders will prevent the majority of carbon dioxide emissions caused by commuter aircraft."



Artist's impression of the Electric Flight Demonstrator. (Credit: DLR/Hendrik Weber, www.wda.de)



Conceptual study of a hybrid electric 19-seater aircraft as part of the CoCoRe research project. (Credit: DLR/BHL)

ONERA

ONERA (Office National d'Études et Recherches Aérospatiales) is the French national aerospace research centre. The organization describes itself as "a public research establishment, with eight major facilities in France and about 2,000 employees, including 1,500 scientists, engineers and technicians. ONERA was created by the French government in 1946 to conduct aeronautical research."

Back in 2015, Onera had advised that a priority research for investment must be in electric aircraft, along with carbon-neutral propulsion and airports. The centre further stated that two research paths in aircraft design must be pursued concurrently: the development of new technologies that could be integrated on all types of aircraft, along with the rethinking of aircraft architectures. The conventional configuration of transport aircraft is dictated by the principle of separating the three main functions of payload (fuselage), lift (wing), and propulsion (engines), enabling each of these subsystems to be treated virtually individually in order to maximize benefits. Since this configuration has probably reached nearly optimum performance, such a configuration offers only very limited room for progress. It is therefore necessary to rethink the problem as a whole, Onera argued, enhancing efficiency by integrating all functions. A change in approach of this type naturally calls into question the current production organization, in which each sector (airframers, engine-makers, and equipment suppliers) enjoys relative autonomy. If the approach advised by Onera were to proceed, it would mean that the industrial landscape and its balances of power would considerably change by 2050.



A concept of distributed electric propulsion on a regional aircraft demonstrator designed for transporting between 4 and 6 people over 500 km in 2 hours. (Credit: Onera)

NASA

NASA (National Aeronautics and Space Administration) is an independent federal agency in the U.S., responsible for the civilian space program, along with aeronautics and aerospace research. A highlight of NASA's work in the electric aviation realm regarding regional electric aircraft is the X-57 Maxwell. The goal of the project is to help develop certification standards for emerging electric aircraft markets. NASA has further described the project as "the first step into a new era of aviation. The project will validate the theory that many propellers ahead of the wing will result in a reduction of five times the energy (including the benefit of battery operation) required for a

private plane at 175 km/h. NASA believes total operating costs can be reduced by 40% with this technology." The project has moved through several steps of ground testing of different systems, flight tests of the different propulsion elements, and a flight test of the full configuration, powered from all fourteen engines, is the next step.

The following are specifications for the X-57 Maxwell:

Performance

- Maximum Operational Altitude: 14,000 feet.
- Cruise Speed: 172 mph (at 8,000 feet)
- Critical Take-off Speed: 58 knots (67 mph).
- Aircraft Weight: Approximately 3,000 pounds.

Batteries

- Lithium Ion.
- 860 pounds.
- 69.1 kilowatt hours (47 kilowatt hours usable)

2 Cruise Motors and Propellers

- 60 kilowatts, air-cooled.
- 5-foot diameter propeller.
- Out-runner, 14-inch diameter.
- 117 pounds each, combined weight.

12 High-Lift Motors and Propellers

- 10.5 kilowatts, air-cooled.
- 5-blade, folding propeller, 1.9-foot diameter propeller.
- 15 pounds each, combined weight.



The X-57 Maxwell in its latest flight test configuration. (Credit: NASA)

In recent developments in 2019, NASA has increased its investment by \$25 million across 10 programs related to electric aircraft technology research.

9.4 URBAN AIR TRANSPORT

Remarkable activity is taking place in a new segment of aircraft called urban air transport or urban air taxi. Probably more than 100 projects are currently designing 1 to 4 passenger vehicles targeting a range of up to 100 km, utilizing vertical take-off and landing (VTOL). The projects are funded by the aviation and car industries, innovative transportation companies like Uber, technology giants such as Google, and a variety of other investors.

Several of the companies are based or have activities in Silicon Valley. Significant investments are being made and nearly all are hiring engineers. There will certainly be some interesting outcomes from all this activity. Both Airbus and Boeing are also participating. Airbus is making test flights with their Vahana project, and Boeing recently bought Aurora Flight Sciences, a maker of automated drones. Most of the projects are based on autonomous and pilot-free flight, but some projects, like Uber Elevate, are indicating that the first flights will be with a pilot.

Uber's strategy is to establish a network of urban air transport in the largest cities, but their plan is not to develop their own vehicle. To get available vehicles, Uber Elevate has established its own team and encouraged competition by entering into intentional agreements with several companies including Aurora Flight Sciences, Pipistrel Aircraft, Embraer, Mooney, and Bell Helicopter, some details of which have been covered previously in this study. Uber Elevate's white paper "Fast-Forwarding to a Future of On-Demand Urban Air Transportation"⁷ gives a good overview of the background challenges for this segment.

⁷ Holden, Jeff, and Nikhil Goel. "Fast-Forwarding to a Future of On-Demand Urban Air Transportation." *San Francisco, CA* (2016).

[https://www.uber.com/elevate.pdf?state=Rdpy_dk1G4SUZOGHuxZI_YD6EYnPUMsPouVLKVmZ8gl%3D&_csid=yIRmOIUhX_uhFLE9kMzTQ#_\[pdf\]](https://www.uber.com/elevate.pdf?state=Rdpy_dk1G4SUZOGHuxZI_YD6EYnPUMsPouVLKVmZ8gl%3D&_csid=yIRmOIUhX_uhFLE9kMzTQ#_[pdf])

A later study by EHang from January 2020 gives good insight into the status of the most important known projects.



The Ehang 216. (Credit: Ehang)

AIRBUS – CITY AIRBUS

According to Airbus, "CityAirbus is an all-electric, four-seat, multicopter vehicle demonstrator that focuses on advancing remotely piloted electric vertical take-off and landing (eVTOL) flight." A full-scale demonstrator of the aircraft conducted its first take-off in May 2019. Again, according to Airbus, "CityAirbus has a multicopter configuration that features four ducted high-lift propulsion units. Its eight propellers are driven by electric motors at around 950 rpm for a low acoustic footprint. The single failure tolerant architecture ensures safety. Its cruise speed will be approximately 120 Km/h on fixed routes with up to 15 minutes of autonomy. It has a capacity of four

<https://www.ehang.com/app/en/EHang%20White%20Paper%20on%20Urban%20Air%20Mobility%20Systems.pdf>

passengers that is ideal for aerial urban ridesharing." As of mid-2020, the CityAirbus sub-scale model had flown more than 100 test flights, which Airbus says has proven the aerodynamic configuration of the full-scale prototype.

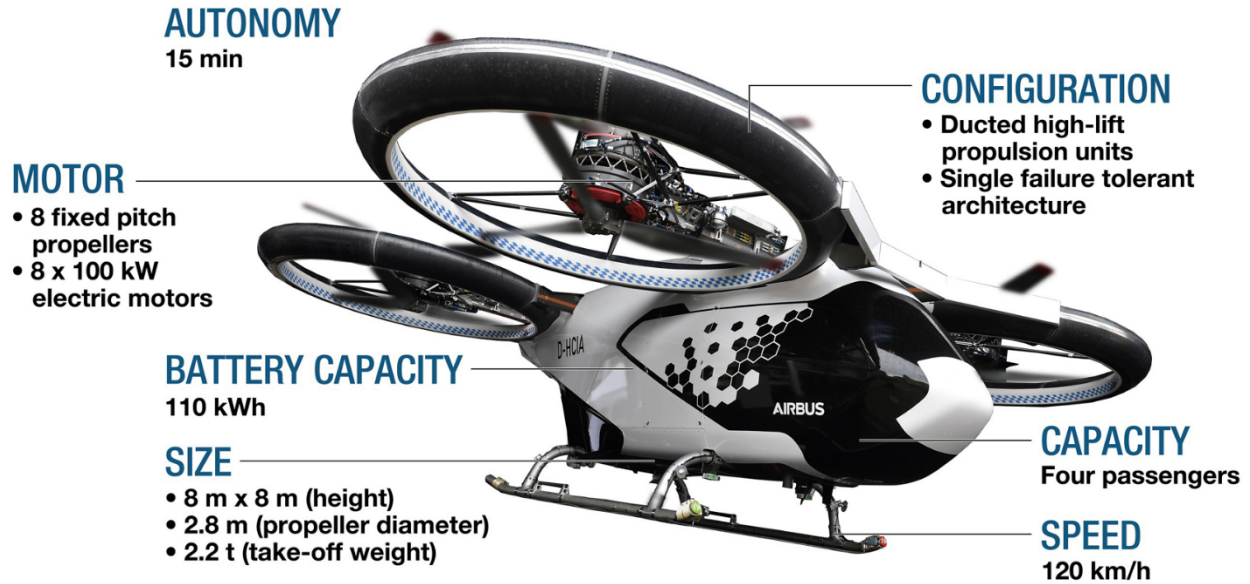

The CityAirbus concept with many technical details provided. (Credit: Airbus)

UBER ELEVATE

Digging a little deeper into the Uber Elevate initiative, its goal is to establish individual, low-cost, urban air transport. The key features of the intended aircraft are: Four seats, fully electric, vertical take-off and 258 km/h (160 mph) top speeds, and a range of about 100 to 160 km (60 to 100 miles). The aerial vehicles will require a safety record nearly as good as a fixed wing General Aviation aircraft. In a second step, the Uber Elevate aircraft shall fly autonomously. In April 2017, Uber held a very successful Elevate conference event, with companies like Bell Helicopter, Embraer, Boeing (Aurora), Hyundai, Jaunt Air Mobility, Joby Aviation, Overair, and Pipistrel all participating, as well as investment companies looking for promising start-ups.



The Uber Elevate vision. (Credit: Uber Elevate)

OTHERS

There are a high number of VTOL activities and projects, maybe as many as 100, and many of them are funded by resourceful investors and capable organisations. The few examples mentioned above are only to give a glimpse of what is going on in this exciting new sector of air transport.

9.5 LIGHT SPORT AIRCRAFT

Most of the development activities for new electric aircraft starts in the segment of General Aviation/Light Sport Aircraft/Recreational Aircraft. This segment allows for more experimental designs and serves as an ideal platform for propulsion testing on the small scale. Siemens is providing systems for this segment, and the all-electric demonstrator Extra 330LE by Germany-based Extra Aircraft had its first flight in 2016 with Siemens systems onboard. Airbus' discontinued E-Fan program, described earlier in this study, started with a full electric one-seater equipped with two electric ducted fans.

Not only does this class of aircraft serve as an ideal testbed for further development, it also had the first fully electric aircraft in serial production: the Alpha Electro from Pipistrel. In Norway, Avinor, in collaboration with NLF, has ordered one Alpha Electro to start a test program as the first step of introduction of electric aviation in Norway. Dozens more Alpha Electros have been produced by Pipistrel, indicating the broad interest in advancing the understanding of electric aviation.

PIPISTREL

As introduced prior, Pipistrel is a Slovenia-based small aircraft designer and manufacturer. The company has existed for more than 30 years and has produced over 2200 aircraft. Pipistrel has long had an interest in electric aviation, having been the first to fly an electric two-seater in 2007. The company followed that innovation up by

winning the NASA Green Flight Challenge in 2011 with the world's first electric four-seat aeroplane. Overall, Pipistrel says it has "designed nine different experimental and serially produced electric aircraft." It is currently selling four different electric aircraft models: the Taurus Electro, the aforementioned Alpha Electro, the Alpha Electro LC, and the aforementioned EASA-certified Velis Electro. Also of note, Pipistrel has developed propulsion systems—encompassing batteries, power controllers, and electric motors—for small and General Aviation aircraft for NASA and Siemens, among others. Pipistrel is also advancing the market of hybrid-electric aviation through its involvement in standardisation committees such as ASTM F44.40, F39.05, and SAE AE7-D.



The Velis Electro, the first certified standard electric aircraft in the world. (Credit: Pipistrel)

EQUATOR AIRCRAFT NORWAY

Equator, a Norway-based company founded in 2010, is developing an electric seaplane designed as a sport utility aircraft with the option of hybrid electric or pure electric aircraft. The testing of the aircraft started a couple years ago with on-ground taxiing. The hybrid propulsion system is being developed through a partnership with German company Engiro GmbH. Equator has received 450 000 euros in government funding through the Norwegian Transnova program.



The P2 Xcursion in flight. (Credit: Equator)

Equator explains that its 2-seat aircraft, named the P2 Xcursion, can achieve performance in line with that of land planes, and at the same time utilize water as a landing surface. The aircraft prototype is pure electric and has a max take-off weight of 750 kg and an 18-kWh battery. The company also has a hybrid underway that will be developed to a fully certified standard through the “FlightSmart” project (2018-2021) that was started through the Norwegian Research Council BIA program, with partners Sintef, NTNU, and Maritime Robotics.

The company is further planning to scale the aircraft to larger types as it gains experience in the light aircraft arena. Aircraft ranging from 4 to 10 seats can be made on the same design properties as the smaller 2-seater version. The work by Equator promises to be an interesting addition to future air taxi systems that could also then include waterways, fjords, and lakes as potential hubs for transport. Finally, the aircraft is also well-suited to become a drone. In this regard, Equator has partnered with Maritime Robotics, a UAV company, in contemplating the development of the P2 into a drone system called the PXdrone.

BYE AEROSPACE

The U.S.-based company, Bye Aerospace, was established by Charlie Johnson, the former president of Cessna, along with a number of other very skilled people from the aviation industry. The company has developed a two-seater, called the Sun Flyer, with an 80-kW motor and a four-seater with a 130 Kw motor. The Sun Flyer's first public appearance was in May 2016. The aircraft is a composite-made, low-wing trainer that features solar cells on the wings, lithium-ion battery packs, and an electric motor.

Under its eFlyer program, Bye Aerospace plans to produce a two-seater eFlyer as well as a four-seater based on the Sun Flyer, currently in process to be fully certified under the new FAR 23 regulations. According to the company website, as of May 2020 there are over 329 paid purchase deposits, split between the eFlyer 2 and eFlyer 4.



The Sun Flyer. (Credit: Bye Aerospace)

OTHER PROJECTS

This Light Sport Aircraft segment overall has a large number of electrification projects at the prototype and testing level.

10. TECHNOLOGY

Electric propulsion for aircraft may accommodate completely new aircraft designs, propulsion systems, and control methodologies, so besides the electric drive system's development, the pursuit of electrification may also foster new innovations. As with all disruptive technology development, completely new solutions that no one has foreseen may ultimately be discovered.

10.1 ELECTRIC PROPULSION SYSTEMS

Electric motors have the potential to replace piston and turbine engines, driving different variations of propellers and ducted fans. Electric engines are scalable in size and may also be integrated with combustion engines (parallel hybrid architectures) to sum power across the two as required. The electric motor responds immediately, and on a multiengine aircraft, it may be possible to replace some control surfaces with motor control, if redundancy and the safety aspects can be maintained. An electric motor will also be able to increase power for short periods for take-off or fault recovery.

The major aircraft engine manufacturers are closely following the activity related to the electrification of aviation. We are likely to see many more announcements like the E-Fan X collaboration previously announced between Rolls Royce, Siemens, and Airbus. In the E-fan X program, Rolls Royce modified a business jet engine, the AE 3007, by replacing the compressor and turbine with a 2 MW electric motor from Siemens.

Different types of propulsion designs may be combined with an electric motor and powered by batteries, a generator set, or a combination of a generator and batteries. We list them below and then describe each thereafter:

- Ducted fans, high-pressure fans (Airbus E-Fan X)
- Ducted fans, low-pressure fans (Airbus E-Fan, Zunum Aero, Bauhaus CE-Liner)
- Ducted fans combined with boundary layer ingestion (Faradair, NASA STARC-ABL, Ampaire)
- Ducted fans combined with distributed propulsion (NASA/ES-Aero, Lilium, Wright Electric)
- Open fan (Safran and other research projects)
- Propellers combined with distributed propulsion (Joby Electric, Volocopter, NASA Maxwell, Eviation)
- Regular propellers

DUCTED FANS

Ducted fans are used by all jet aircraft, business jets, and airliners that are powered by an inline turbine engine. These ducted fans are high pressure turbofans, designed for high speed transonic cruise. The vast majority of fan development work over the past decades has been focused on increasing the bypass ratio on large turbofan engines. While the higher bypass does lead to a lower pressure ratio, the fans are still optimized for large transport aircraft flying long range at high speed.

For regional aircraft with under 90 seats, propellers powered by turboshaft engines are the most common solution. Limited engineering efforts have been spent on ducted fans optimized for these size ranges, which require much lower pressure ratios to achieve highly efficient propulsion.

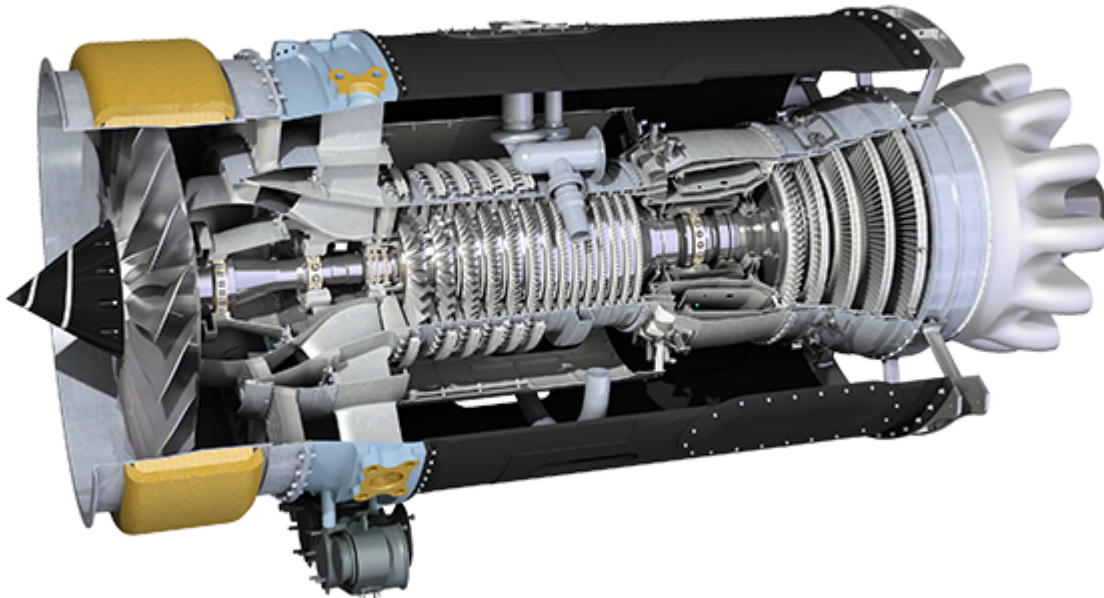

The Rolls Royce AE 3007 engine, originally used for Cessna Citation and other business jets. The compressor and turbine were replaced by a 2 MW Siemens motor in the E-Fan X program. (Credit: Rolls Royce)

Zunum Aero has been developing a low-pressure ducted fan for their size range of aircraft (9 to 50 passengers) and according to Zunum's experienced development team, there is a strong engineering basis for achieving efficiencies better than open propellers for cruise speeds above 200 kts. This view is also backed by Airbus, which had selected two ducted fans to power the electric engine in their former E-Fan project, as well as for the now terminated E-Fan X program, which was designed for higher speeds but still substantially lower pressure ratios than the turbofans being replaced.

An electric ducted fan has the potential to significantly reduce noise and at the same time increase static thrust for improved acceleration and short take-off. Noise sources are primarily the tip speed of the fan and jet velocity from the combustion core. With an electric fan, tip speeds are much lower, optimized for aero efficiency without having to match a turbine cycle, and there is no combustion jet. Compared to an open propeller, tip speeds are lower and frequencies are higher, which leads to faster sound dissipation, and most importantly, the dominant tone from the propeller-tip is blocked by the duct. In addition to noise benefits, the duct provides higher thrust during the take-off roll than an equivalent open propeller, resulting in a shorter take-off distance. The compact design reduces cost of the structure and enables very efficient integration with a variety of aircraft designs.

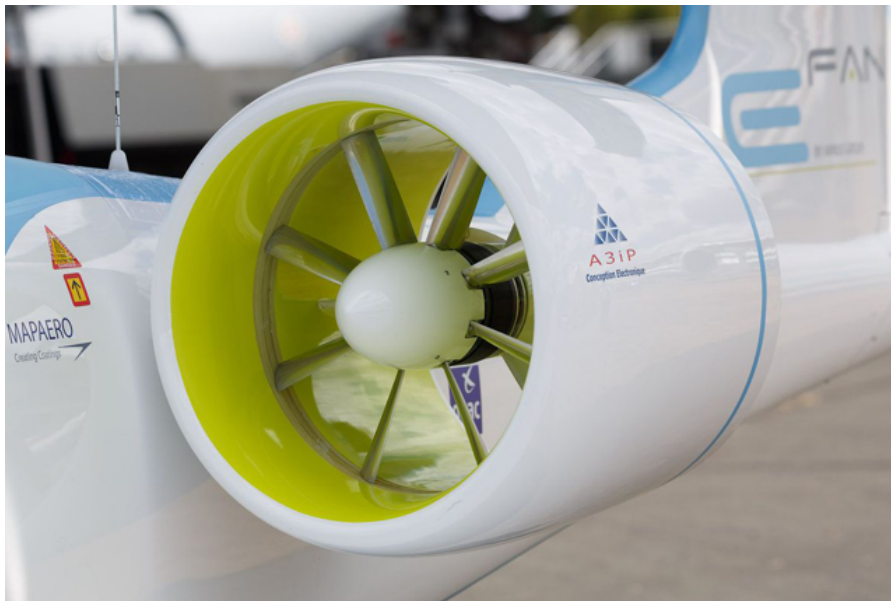

The Airbus E-Fan project used two ducted fan modules. (Credit: Airbus)



Zunum Aero is developing low thrust ducted fans for their new aircraft. (Credit: Zunum Aero)

BOUNDARY LAYER INGESTION

Ducted fans have also been coupled with boundary layer ingestion (BLI) concepts for efficiency, although the engineering of these is far less developed. The boundary layer refers to the layer of slow-moving air that develops on the skin of an aircraft as it flies. The slow air creates drag. Aircraft today just accept this drag because with internal combustion engines, it is more efficient to place them away from the aircraft body's boundary layer—for instance, out on the wings—in order to have faster-moving air enter the motors.

The BLI design suggests doing the opposite by positioning an engine to ingest the slower air passing around the fuselage. The result is overall lower drag and thus reduced fuel or energy consumption. So far, research into this method has indicated an overall drag reduction nearing 10%, which is considerable.

BLI engines could be placed at the extreme rear of the aircraft, right on the fuselage, where they can ingest the thickest portion of the boundary layer and help an aircraft get back some its drag losses. There are several challenges to overcome, but aerodynamic experts are bullish that this design will be implemented for future aircraft.

While there are theoretical efficiency gains to be made with BLI, these can be significantly reduced by real world installation effects, and also result in higher noise and structural challenges for the fan. These are compounded in the low-pressure fan, where the total efficiency is even more sensitive to distortion in the airflow.



The Faradair BEHA (Bio-Electric-Hybrid-Aircraft), a 6-seat aircraft with a hybrid propulsion system. (Credit: Faradair)



The NASA STARC-ABL, which stands for Single-Aisle Turboelectric Aircraft with Aft Boundary Layer propulsion. (Credit: NASA)



The Ampaire team has designed their futuristic aircraft with a tail electric ducted fan. (Credit: Ampaire)

DISTRIBUTED PROPULSION

Other ducted fan concepts leverage distributed electric propulsion (DEP), which is enabled by scalable electric motors that are easy to integrate. This technology may open a new avenue for aircraft design from the largest to the smallest aircraft and is most advantageous on various vertical take-off and landing (VTOL) designs. DEP may also include small ducted fans, like on the Lilium project, or on larger aircraft like the intended design of aircraft from the partnership between U.S. start-up Wright Electric and British airline EasyJet.



An example of a distributed electric propulsion design from Empirical Systems Aerospace (ESAero) for NASA. (Credit: ESAero)



An EasyJet concept designed with DEP by Wright Electric. (Credit: Wright Electric)



Lilium project using DEP for VTOL aircraft. (Credit: Lilium)



Joby Aviation S2 VTOL. (Credit: Joby Aviation)

NASA is testing an experimental 31-foot aircraft wing with 18 electric motors placed along the leading edge. This unusual setup is called Leading Edge Asynchronous Propeller Technology (LEAPTech), and according to NASA this could result in a new and more energy-efficient propulsion system, which may be an enabler for new aircraft designs. The project (introduced prior in this study) is named X-57 Maxwell, and after testing of the new wing equipped with the propulsion system on the ground, it will replace the original wing of an Italian TECNAM P2006T twin-engine four-seat aircraft to be used as a testbed.



NASA's X-57 Maxwell will be powered by a battery system that consists of 16 battery modules. The system will comprise 800 pounds of the aircraft's total weight. X-57 will demonstrate that electric propulsion can make planes quieter and more efficient, with fewer carbon emissions in flight. (Credit: NASA)

As described in an Electrek article, "NASA's aeronautical innovators hope to validate the idea that distributing electric power across a number of motors integrated with an aircraft in this way will result in a five-time reduction

in the energy required for a private plane to cruise at 175 mph." The majority of this reduction is from the efficiency of the electric powertrain with the remainder due to anticipated benefits of the distributed propulsion and reduced wing size. In addition.

OPEN ROTOR SYSTEM

Another intriguing idea is an open rotor system. As described in an *AIOnline* article from October 2017, "The breakthrough of the open rotor stems from a significant increase in the bypass ratio, from 11:1 on the Leap to more than 30:1. The lack of a nacelle covering makes it possible to increase the size of fans, thus the increase in bypass ratio. The higher the bypass ratio, the better the energy efficiency of the engine. The disadvantage lies with the need to completely reconfigure the aircraft and possibly noise profile. An open-rotor engine cannot mount on a wing, but must attach to the rear of the fuselage."



Safran open-rotor demonstrator. The engine configuration could burn 15 percent less fuel than the CFM Leap. (Credit: Safran)

PROPELLERS

Open propeller technology has steadily developed since the very beginning of aviation. It is highly efficient at low- to medium-speeds and is used on a large number of aircraft. The combination of a propeller and an electric motor is ideal. The electric motor responds instantly with high torque and may also provide a short power boost for ~30 seconds. In combination with variable pitch, this is a very flexible and powerful propulsion system for low- and medium-speed aircraft.

When it comes to noise, the experience from piston engine aircraft has shown there to be a significant noise reduction due to the absence of the exhaust and the inherent engine racket. It is also expected that turboprop aircraft will get reductions in high tone noise from the turbine and exhaust outlet. In both cases, the propeller noise will naturally depend on advanced propeller designs optimized for low noise.



Electric engine with propeller seen on NASA's X-57 Maxwell's wingtip cruise motor/propeller. (Credit: NASA)

WINGTIP MOUNTED PROPULSION

Accommodating the wingtip is a very challenging part of aircraft design. The pressure differences above and below the wing create a significant drag and a vortex behind the wing. Additionally, this effect disturbs and reduces lift at the outer wing surface. Different wing tip devices, such as like winglets, are used to reduce the effect. The introduction of electric propulsion could leverage this technique by mounted the engine units themselves right at the wingtips, thus reducing drag and neutralizing vortex formation. A secondary benefit could be that reducing the strength of wingtip vortices also reduces turbulence, which can pose a possible hazard to aircraft following behind.

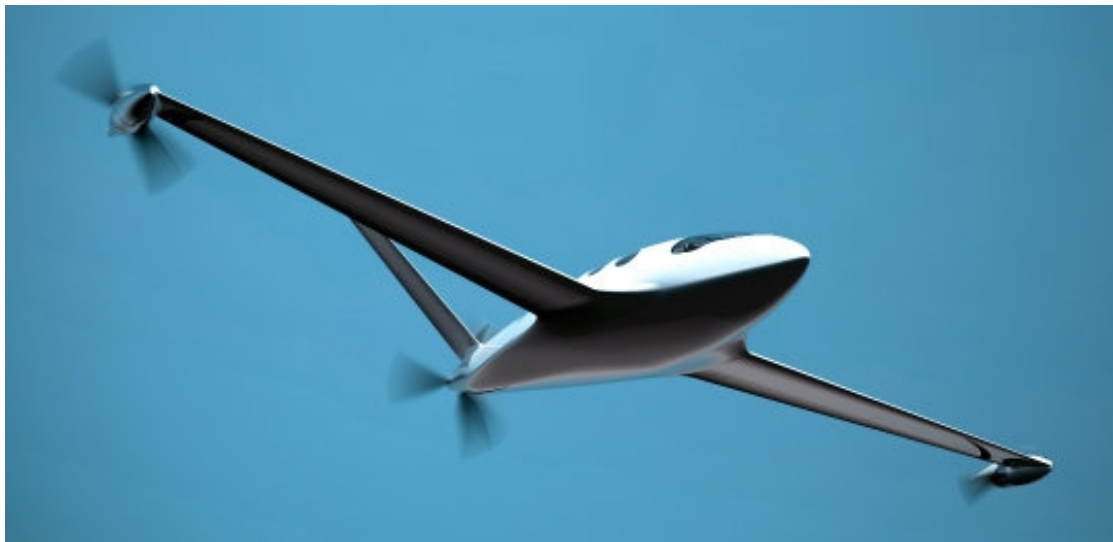

Eviation aims for a highly efficient composite aircraft with wing tip and tail electric propulsion. (Credit: Eviation)

10.2 DRIVE SYSTEMS AND ELECTRIC MOTORS

Although power electronics that are used to control electric motors are based on well-known technologies, they still must be further developed to meet the coming requirements for reliability, safety, performance, and

regulation for aircraft. Experienced aviation industry suppliers like Rolls Royce, Safran, and others are working on new high-performance electric drive and propulsion systems. GE has designed an advanced 1 MW hybrid system with a turbo generator and a super-efficient (98%) electric motor for propeller propulsion. It should be expected that more of these sorts of projects will be forthcoming from the aviation industry soon.

As standards and regulations today do not cover electric propulsion, there is a significant challenge to establish new rules and further to match the many ongoing technology developments to these new standards. The segment of General Aviation and Light Aircraft is important for this development activity. The first projects in this segment have replaced the combustion engines in existing aircraft with electric motor power electronics. A variety of in-house development, along with companies supplying drive systems components to those projects, is providing valuable experience both for regulatory purposes and system designs.

ROLLS-ROYCE

Rolls-Royce, according to the company, "has customers in more than 150 countries, comprising more than 400 airlines and leasing customers, 160 armed forces, 70 navies, and more than 5,000 power and nuclear customers. Annual underlying revenue was £15 billion in 2018, around half of which came from the provision of aftermarket services. In 2018, Rolls-Royce invested £1.4 billion on research and development. The company also support a global network of 29 University Technology Centres."

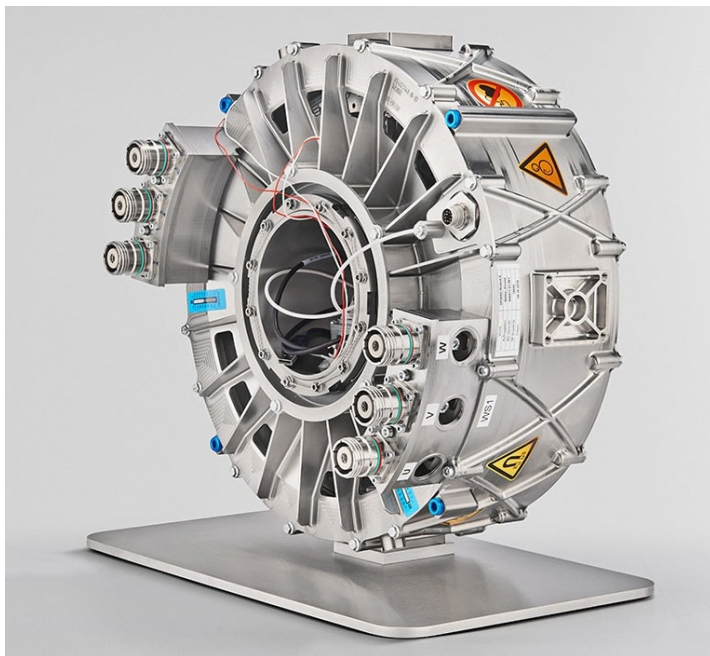

Rolls-Royce direct drive 260 kW electric motor, with a weight of 50 kg. (Credit Rolls-Royce)

Rolls-Royce's strategy is to become a system supplier for electric and hybrid electric aircraft and to supply complete drive trains, including power electronics and motors as well as battery pack design and integration including BMS (Battery Management System). According to Rolls Royce, hybrid electric propulsion may have the potential to reduce block-energy by up to 20% compared to conventionally powered aircraft and significantly reduce CO₂, NO_x and noise emissions.



ACCEL project concept. (Credit: Rolls-Royce)

Among a range of projects, here are a few examples:

- ACCEL. Rolls-Royce is leading this project to build the world's fastest all-electric aircraft. The zero-emission aircraft, nicknamed the 'Spirit of Innovation,' is expected to make a run for the record books with a target speed of more than 300 mph (480 kph).
- APUS i-5. This project will demonstrate the practical application of hybrid electric technology for a 4 000-kg (8 815-pound) conventional take-off and landing flight test vehicle. The system could be used across a range of transport platforms to enable distributed electric propulsion, including hybrid electric vertical take-off and landing vehicles, General Aviation aircraft, and hybrid helicopters.
- The AE 2100 Hybrid 2.5MW system is being developed for larger aircraft, including regional aviation. Rolls-Royce engineers based in the United States, UK, Germany, Norway, and Singapore have developed the AE2100 engine into a hybrid-electric propulsion system. It was initially to be tested on the Airbus E-Fan-X demonstrator platform but now is to be tested in a ground test.



APUS project concept. (Credit: Rolls-Royce)

SAFRAN

Based in Paris, France, Safran is an international high-technology group with more than 95,000 employees and sales of 24.6 billion euros in 2019. The company has operations in aircraft propulsion and equipment, as well as the space and defence markets. Total R&D expenditures at the company in 2019 were approximately 1.7 billion euros.

Safran has an active role in several electric propulsion projects and is likely to be an important player as the technology and new solutions take form. On its website, Safran states that "Full hybridization will involve developing more powerful thermoelectric systems that will directly provide lift and forward thrust for the aircraft, as well as power its non-propulsive functions. The final destination will be all-electric propulsion, where conventional combustion engines will be completely superseded by a purely electric power source. The actual timetable for the entry into service of electric aircraft depends on multiple factors. Safran is planning ahead for these long-term step changes in the market, starting with shorter-range and more limited solutions, while awaiting technologies that are mature enough to store and deliver the electrical power needed for propulsion."



(Credit: Safran)

MGM COMPRO

MGM COMPRO, a Czech Republic company, has developed electric propulsion units ranging from large systems to special custom-made units for Airbus, NASA, and a number of other organizations' electric aircraft projects. As the company states on its website, "MGM COMPRO innovative concepts bring a lot of advantages for every project of our customers, whether it comes to electric propulsion systems for airplanes, gliders, vehicles, boats, multicopters, UAVs, military vehicles, other EVs or any unique designs according to customer's special needs."



MGM Compro drive systems. (Credit: MGM)

GENERAL ELECTRIC

General Electric (GE) has a strong position as a supplier of electrical power solutions for aircraft. The company has previously published a whitepaper on hybrid solutions for electric aircraft and is expected to play an important role in the years ahead. In the white paper, GE describes how it has modified its F110 engine (used in F-15 and F-16 fighter jets) to generate 1 MW of electric power. For propulsion, GE has also designed an advanced 1 MW electric motor with a propeller designed by Dowty, a GE subsidiary. Flightglobal, an online news aviation news site, offered the following characterization: "[t]his hybrid system could produce the same thrust as a large version of the Pratt & Whitney Canada PT6A turboshaft engine. The motor itself represents the state of the art in efficiently converting electricity into power. Whereas most aviation motors are designed to achieve 90% efficiency, the new motor demonstrated by GE is 98% efficient, the white paper claims. Importantly, such efficiency means a 1MW motor produces only 20kW of waste heat, rather than at least 100kW if a conventional aviation motor is used. GE has not revealed the size or weight of the device. By comparison, the Boeing 787 uses six generators to produce a maximum load of 1.4MW of electric power, which the aircraft uses to provide power for de-icing the wing and engine nacelles and pressurising the cabin."

MAGNIX

Headquartered in Redmond, WA with engineering facilities in Redmond and in Australia, magniX is dedicated to connecting communities by enabling an era of clean and affordable commercial air travel with all-electric propulsion. magniX has developed a family of electric propulsion systems for commercial aviation solutions including the 375HP and 750HP all-electric motors various aviation applications either single motor application or as part of a multi-motor aircraft.

A 208B Cessna Grand Caravan developed in partnership with AeroTec, powered by a 750HP magni500 propulsion system, became the world's biggest all-electric commercially focused aircraft when it took to the skies in May 2020 at Moses Lake, WA.



The first flight all-electric commercially focused aircraft. (Credit: magniX)

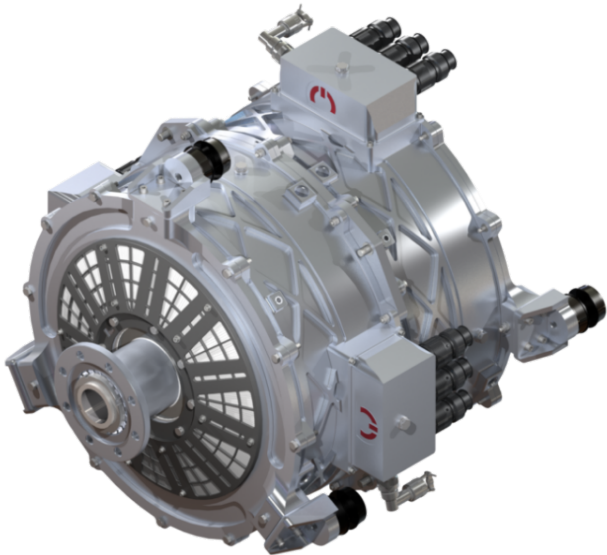

The 560 kW magni500 motor. (Credit: magniX)

EMRAX

Based in Slovenia, EMRAX is one of the earliest electric motor suppliers to the aviation industry. Its products are currently used in powered sailplanes and light aircraft like the SORA-e. The company offers lightweight direct drive propulsion units from the 10s of kW up to 300 kW of peak power, or EMRAX TWIN variants with double the power.

The motor design is based on axial flux synchronous permanent magnet motors and generators that operate on the basis of patent-pending technology. The company is supplying a number of drive systems to gliders.

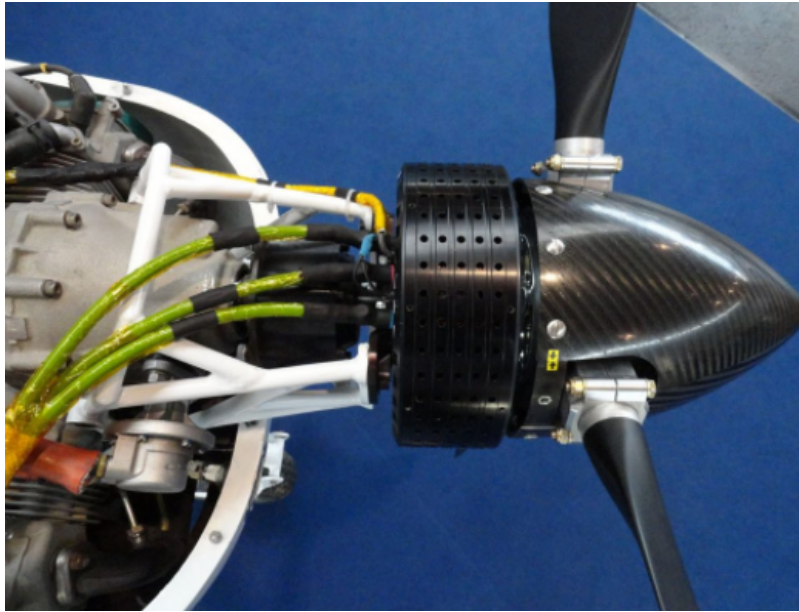

Emrax electric motor. (Credit: Amrax)

10.3 HYBRID ELECTRIC PROPULSION SYSTEMS

The hybrid electric approach to propulsion is expected to be introduced in commercial aviation, both for smaller and larger aircraft, within the next ten years. Batteries may not yet have the necessary energy density to replace liquid fuel entirely in that time span. But even today's technology can store sufficient amounts of energy to provide additional power for larger aircraft and enough energy for shorter regional flights.

As energy density continues to increase, the battery-stored energy will play a growingly important role. To specify, this role will likely range from additional electric power for the fan section in large turbofan engines, to onboard generators that can be called upon as energy reserves to extend flight distances. At the same time, the combustion engine can be used to provide extra power during take-offs and ascents, when energy requirements reach peak levels during aircraft operation.

It is important to emphasize that a hybrid electric aircraft may function as a pure-electric aircraft, with the combustion engine and generator not being used at all and only standing by as a spare energy source if needed. Hybrid electric cars often operate in the same way, for example when driven for a daily commute to and from a work site that is within their batteries' range and charged from the grid when parked. The combustion engine just sits there within the vehicle in a reserve capacity, to be used perhaps on a long leisure trip on the weekend.

For an electric aircraft, such a configuration makes even more sense than for a car. To operate a commercial flight with passengers, an aircraft must maintain a significant energy reserve. In case of bad weather or problems at the intended destination airport, for instance, the flight may have to return or divert to another airport and need much more energy than for the original flight.

A pure electric aircraft could carry surplus batteries in order to have the required energy reserve. For a hybrid electric aircraft, this required energy reserve is instead a combustion engine and generator, often called a "range extender."

In the near future, range extenders and their liquid fuels will likely weigh and cost less than the batteries that would offer the equivalent range extension. As energy densities improve, the weight and cost equation will change to favour batteries, making combustion-based range extenders technologically and economically obsolete.

An additional use for electric propulsion via the hybrid electric approach is to engage the electric drive when taxiing on runways and otherwise moving the aircraft on the ground. Doing so reduces the emissions of greenhouse gases and other pollutants at ground level, where in the latter case they reach into the surrounding community.

Based on the arguments presented above, it is quite likely that the first regional commercial passenger aircraft will be designed as hybrid electric, although in practice they may usually operate in a pure-electric mode. For larger, long-distance aircraft, hybrid electric solutions are likely to be introduced in order to reduce fuel consumption as well as reduce emissions during ground operations.

To summarize, hybrid electric solutions for aviation can serve numerous purposes:

- a) Reduce overall fuel/energy consumption by adding electric power from batteries to avoid combustion engine operation.
- b) Eliminate pollution at and around airports by electrically powered ground handling.
- c) Provide additional power from combustion engines when required during take-off and climb.
- d) Enable longer flight distances with the combustion engine and generator working as a range extender.
- e) Maintaining an emergency energy reserve for when the battery-based range and power capacities are to be exhausted.

In general, hybrid electric systems fall into two categories, parallel and serial.

Parallel hybrid

This hybrid electric system is characterised by a mechanical connection between the electric motor and the combustion engine, which both add power for propulsion. The majority of hybrid electric cars utilize this design. As the combustion engine and electric motor are mechanically coupled, the electric motor can serve the purpose of being both motor and generator. The battery pack onboard delivers power and can be charged as required. Typically, the electric motor will provide additional power during acceleration and take-off, but may serve as a generator during descent.

Serial hybrid

In contrast to a parallel hybrid system, a serial hybrid system is characterised by a separate combustion engine (piston or turbine) connected to a generator, whose only purpose is to produce electricity for the battery pack. The propeller or ducted fan for propulsion is driven by electric motors only. This configuration allows for a variety of promising propulsion designs, as described in other sections in this study.

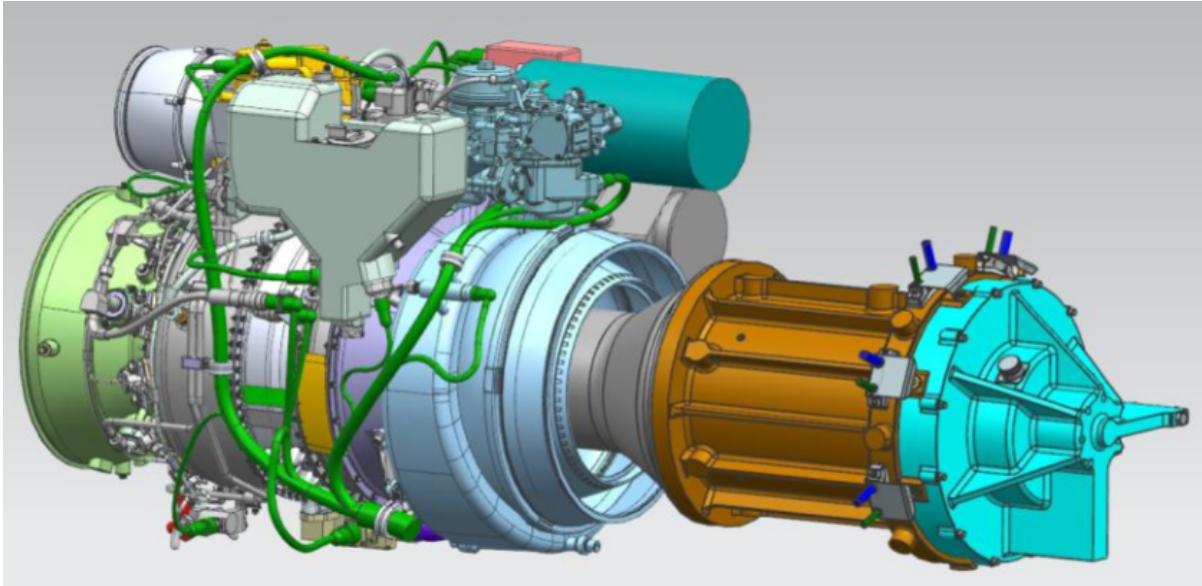

A concept design from Honeywell for a 1 MW turbo-generator range extender, based on existing technology. (Credit: Honeywell)

A final point to make in this section is that electricity production onboard an aircraft is of course not a new idea; nearly all aircraft have an APU (Auxiliary Power Unit) to supply electricity. Newer aircraft have systems and actuators that are no longer hydraulic-based and instead run on electricity. For example, the Boeing 787 is the first aircraft with an electrically powered air conditioning system, electrically powered brakes, and an electrically powered de-icing system. Integration of a range extender in a hybrid electric aircraft will be similar to an APU, and therefore be mainly covered by existing regulations and standards, thus easing adoption.

As mentioned prior, Rolls-Royce started in 2019 the development of a hybrid-electric flight demonstrator using its M250 propulsion system. The demonstrator is based on the proven M250 gas turbine engine used on more than 170 models of conventional helicopters and airplanes. Integrating a high-energy-density battery system, electric generators, power converters, and an advanced power management and control system, the 500-kW to 1-MW system will be installed in the APUS i-5 airplane to demonstrate the application of the technology for a 4 000-kilogram (8 815-pound) conventional take-off and landing flight test vehicle.

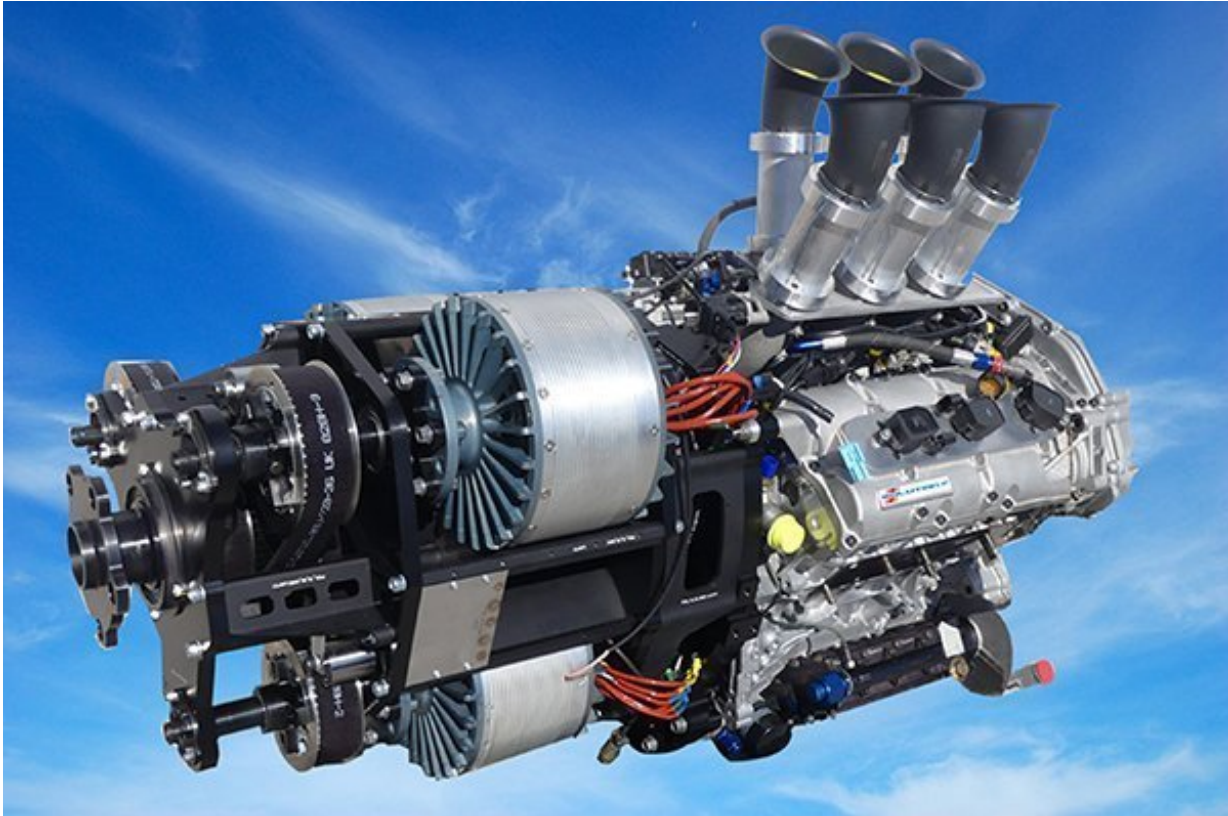

VoltAero's hybrid power module combines the power of an internal combustion engine and three electric motors. (Credit: VoltAero)

10.4 NEW AERODYNAMIC OPPORTUNITIES

Electric propulsion may allow for entirely new aircraft designs, some already proposed and others that have not even been thought of yet.

For cars, an electric drive train is just another way to propel the wheels; there are no radical changes to the concept of a car's basic shape or design, as such. The situation may be entirely different for aircraft, which is one more reason for the enthusiasm regarding the electrification of aviation. Through a reimagining of the traditional form factors long dictated by combustion engines, electric propulsion may foster disruptive change in aircraft architectures, ushering in not only far more efficient designs than today's, but with aesthetics and consumer-oriented styles.

One especially opportunity-enabling design approach is distributed electric propulsion (DEP), where smaller engines, placed in significant number almost anywhere on a fuselage as desired to gain efficiencies, combine to yield the necessary thrust. A second design concept that electrification could advantageously enable from an aerodynamic perspective is wingtip-mounted propulsion units. Another new direction is Boundary Layer Ingestion (BLI), where the engines are placed directly on the fuselage to reduce efficiency-harming drag.

More details are covered under the propulsion systems section of this study.

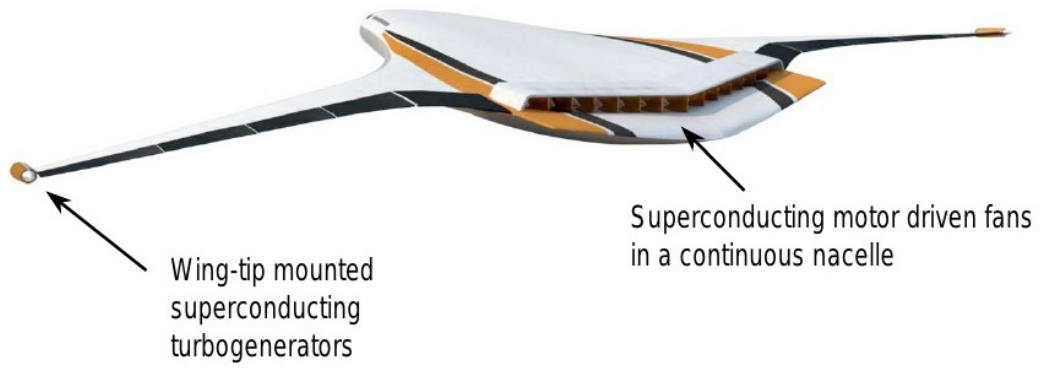

Concept for NASA's N3-X Distributed Turboelectric Propulsion System. (Credit: NASA)

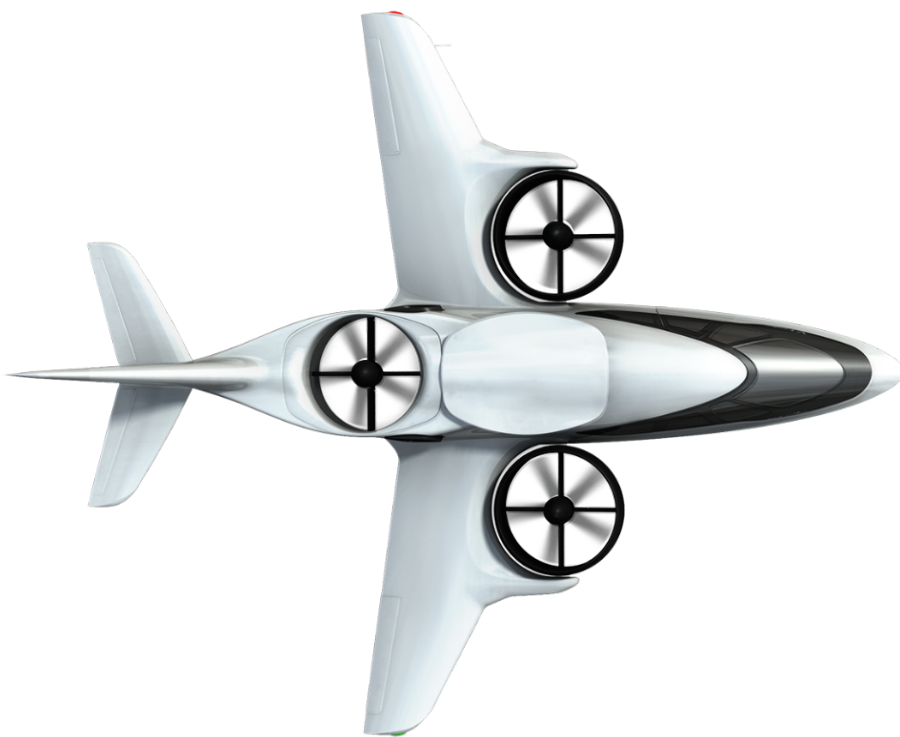

XTI aircraft, a 5-seater, hybrid electric VTOL plane utilizing the flexibility granted by electric motor propulsion. (Credit: XTI Aircraft)



An example of distributed propulsion with the Aurora unmanned drone, which uses 24 distributed ducted fans and a tilt wing design. (Credit: Aurora)

PRANDTL PLANE CONCEPT

For a given wingspan and lift, the Prandtl-type biplane concept by Onera, which has its wings connected at the tip, provides a theoretically induced drag reduction of about 20% during low-speed phases such as take-off, climb, descent and landing. Such a configuration might be an interesting solution for short take-off and landing short-range aircraft with less range than today's Airbus A320 or Boeing 737. The potential benefit of this radical change in configuration might be a reduction of up to 10% in fuel burn, so long as weight is not increased compared to a conventional aircraft. This concept provides also new solutions for engine integration.



The Prandtl Plane Concept. (Credit: Onera)

11. ENERGY CONSUMPTION AND GREEN HOUSE GAS EMISSIONS

With the aviation industry highly focused on emissions and fuel consumption, the specific energy consumption for aircraft has been improving for each new engine generation. The industry's customers are pushing hard as fuel is a large proportion of their expenses in the harshly competitive commercial aviation market. Additionally, politicians and governments are urging the industry to take their part in the overall societal responsibility to reduce global greenhouse gas emissions.

The rapid development of batteries and the race towards electrification in the automotive industry is clearly recognized by the entire aviation community, which is not wasting time and has for several years now been working on designs and solutions to bring about the electrification of aircraft as well.

The advantages are obvious and not very much debated. In general terms, the efficiency of combustion turbine/piston engine is in the range of 20% and up to 40%, depending on aircraft and flight mode. Short regional flights with traditionally designed turboprops are on the lower end, while long haul flights with new modern turbofan engines are on the high end.

Electric motors for propulsion power for aircraft is already understood to be at 85 – 90% efficiency and may yet be slightly further improved by superconductive materials. An interesting feature of electrification is that the efficiency remains at the same high conversion rate for smaller as well as larger propulsion system and is independent of flight levels. As a result, regional aircraft and short flight routes may become as energy efficient per passenger kilometre as long-haul flights. Electric motors are particularly more efficient during taxiing on the ground and in the descent phase of flight than turbine engines.

In terms of greenhouse gas emissions, electric aircraft also offer good news. Reduced specific energy consumption means reduced emissions. The use of power from batteries eliminates operational emissions for pure-electric aircraft and reduces emission from hybrid electric aircraft.

The graph below compares specific energy consumption where all numbers are converted to the energy term kilowatt hours (kWh) and the energy is either from jet fuel or electricity.

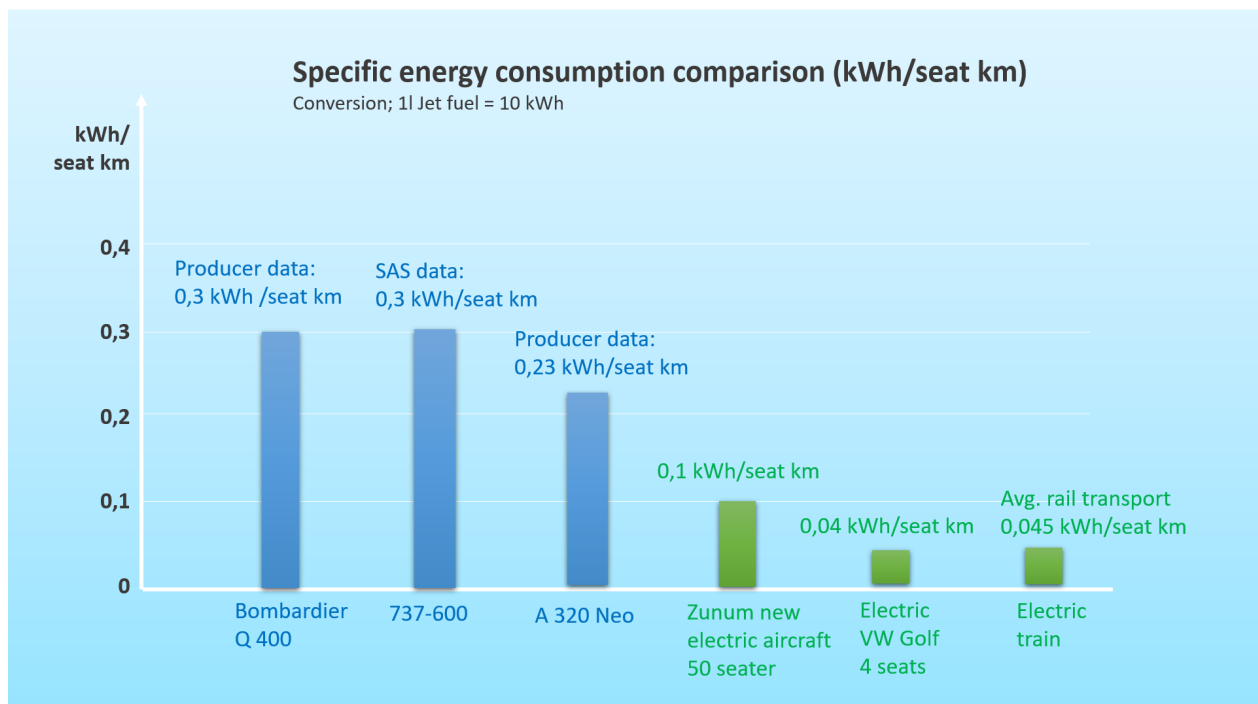

Specific energy consumption (kWh / seat km) for different aircraft and transport modes. Numbers are from producer's information, either from web pages or direct information. Numbers for VW Golf are based on assumed energy consumption of 0,16 kWh/km. Numbers for rail are from 2017 High-Speed Rail and Sustainability: Decision-making and the Political Economy of Investment by Blas Luis Pérez Henríquez and Elizabeth Deakin. (Graphics by Green Future AS)

11.1 ENERGY CONSUMPTION AND EMISSIONS OF HYBRID ELECTRIC AIRCRAFT

Reduction of specific energy consumption and emissions for hybrid electric aircraft will depend on how much energy is used from the grid and batteries versus how much is used by the fuel-powered range extender. Even for regional hybrid electric aircraft that do not utilize grid power, however, it is expected that the efficiency of a turbo generator (range extender) at optimal load will outperform traditional turboprop propulsion. Additionally, a serial hybrid aircraft may take advantage of new aircraft designs for even more energy efficiency.

As a consequence, it is expected that a hybrid electric aircraft will outperform today's designs. When regulatory matters are sorted out and certified propulsion systems become available, a relatively rapid transition to new aircraft designs therefore seems likely.

Regional aircraft in the range of 12 – 80 seats are the most straightforward to electrify and may be the most beneficial in the short term. This segment, with operations consisting of short, 30-minute flights, is likely to be operated by hybrid electric aircraft. (Likely very similar to the majority of the operations by Widerøe, the largest regional airline in the Nordic countries.) These aircraft will have cruise speeds in the range of 450 to 700 km/h (280 to 400 mph) where the battery weight will be 25 to 30% of the total take-off weight. For a 50-seater with a take-off weight of just above 20 tons, the battery weight may be 5 tons for a pure electric and slightly lower for a hybrid electric.

There is limited information available for all the different projects, but what is available is still fairly consistent in the specific energy consumption range of 0,1 – 0,15 kWh / seat km for aircraft from 9 – 50 seats. It is difficult to quantify expectations for new aerodynamic features like distributed electric propulsion, boundary layer ingestion, and wing tip propulsion, though those new designs are yet to be developed and have to be tested in aircraft configurations to validate any improvements.

Calculations have been made to understand energy consumption in different modes of the flight like taxiing, take-off, climb, cruise, descent, landing, and taxiing to the gate. For short flights, the electric aircraft has great benefit with regards to reduced energy consumption at trip initiation and taxiing and particularly at descent. An electric aircraft can descend with virtually zero propulsion power and even some regeneration.

To illustrate expected performance, comparisons of flights from Stavanger to Bergen have been made. The calculated flight distance is 190 km (slightly longer than the direct line between the two airports). Fuel consumption for a real flight with a Widerøe Dash 8 is 220 kg Jet A-1, representing 2 640 kWh (1 kg Jet A-1 = 12 kWh). Now considering a smaller electric 19-seater proposed by Aura Aero, based on a simulation for the 190 km flight, the energy consumption comes out at approximately 450 kWh.

Looking at the prospected battery capacity for the 19-seater Aura Aero electric aircraft, this may allow a capacity of 1 000 kWh (2 000 kg battery with energy density of 500 Wh/kg) or more with higher battery density. Even if designed for hybrid electric propulsion with lower battery capacity, the aircraft may be operated as a pure-electric with a “sleeping” range extender as reserve. In practical terms, this means that the hybrid electric aircraft can operate by battery only and in the example above, perform the flight without engaging the range extender. The same will be the case for a majority of routes in the PSO network of airfields, where range extenders will be kept as a “sleeping” reserve.

A further reason for this propulsion arrangement being efficient is that the weight of the range extender and fuel is much lighter than the weight of a comparable battery energy reserve. The reserve is of course very important for any passenger flight to be able to divert to an alternative airport or return to base if for some reason it is not possible to land at the intended destination. For short flights, this will be a proportionally large part of the energy reserve, and maybe twice as much energy as is required for the intended flight itself.

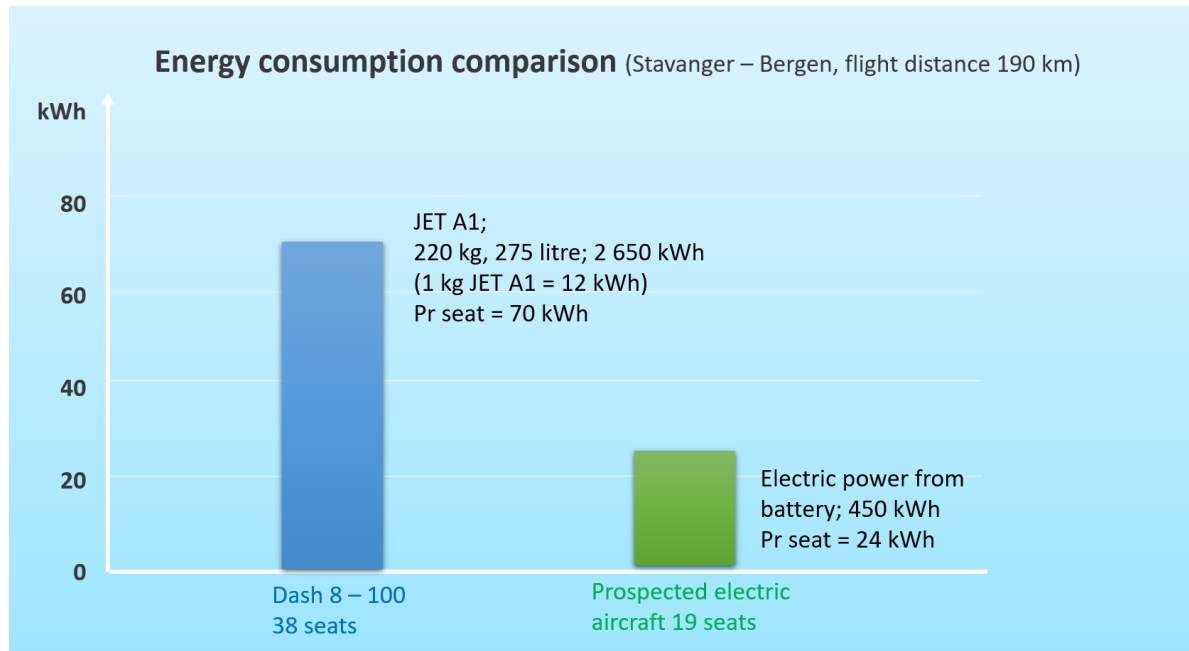

Energy consumption comparison between a real Widerøe flight (Dash 8-100) and a proposed electric 19-seater for a flight from Stavanger to Bergen. (Graphics by Green Future AS)

11.2 REDUCED EMISSIONS

From a Norwegian perspective, it will be possible to operate many regional flights just on pure electricity. Those flights may be done by an electric aircraft with a “sleeping” range extender, while a smaller number of flights may involve the range extender as well. Overall, emissions would be significantly reduced in comparison to using conventional propulsion systems.

The emissions reductions will be based on how much electricity is charged from the grid and how much fuel is consumed. Over the last 5 years, fuel consumption for Norwegian domestic air transport has been in the range of 500 mill litre yearly, corresponding to around 1,3 mill tons of CO₂ emission equivalents. Roughly 15% is related to Widerøe operations, representing 180 tons CO₂ equivalents.

The fuel consumption for domestic traffic has reduced slightly since 2014 and may be expected to stabilize or trend downwards for the next decade, as older aircraft are replaced by newer, more energy-efficient models and biofuels become more widely used.

It is very important to encourage this transition as soon as possible because each year that the transition is moved up will save a significant amount of emissions—about 1,3 mill tons of CO₂ emission equivalents annually, as just mentioned.

12. ECONOMICS

As stated previously in this study, aircraft with electric propulsion are expected to have lower operational costs, longer maintenance intervals, and lower engine maintenance costs compared to conventional systems. As there are of course no experiences with electric aircraft in significant commercial operation from which to draw upon, these assumptions must be based on experiences involving other products. From such experiences, electric drive systems are clearly preferred in virtually every application where electric power is an available option. There is also no doubt that electric motors are both more reliable and, in most cases, require comparatively minimal maintenance. Furthermore, energy/fuel costs are significantly lower with an electric aviation solution.

12.1 ACQUISITION COST

It should be expected that from a materials and manufacturing perspective, electric motors will be less costly than turbine engines. Overall, though, the total drive system with power electronics, cooling systems, and subjection to certification processes may end up not very different cost-wise compared to the systems of today. Working in the wrong direction is the additional weight of batteries, which will proportionally require more propulsion power and structure strength.

It must also be taken into account the significant, up-front research and development work that will have gone into introducing electric aircraft to the market, and that at first will need to be amortised over a relatively limited number of drive systems. The aviation industry does not have the volume advantage of the automotive industry, and aircraft components are much more expensive in comparison to cars.

All things considered, in the short term it should be expected that acquisition costs of electric aircraft will be higher than those of traditional aircraft. That said, when the technology is more mature, the volume is going up, and there is sufficient competition among suppliers, then the price should have the potential to come down.

In this early phase, it will be important that governments establish a framework of good incitements to encourage the transition as soon as possible to reduce CO₂ emissions. Time is of essence and every year counts.

12.2 AIRCRAFT LIFE

Electric propulsion is not expected to have an influence on the design life of the aircraft, other than there being some indications that less vibration compared to combustion engine craft will reduce airframe fatigue in some sections.

12.3 MAINTENANCE COST

All components for electric aircraft will be designed according to the high safety standards mandated by the relevant regulatory authorities. Given the degree of reliability expected by the market for modern aviation, all components such as the electric motors, power electronics, and cooling systems will need to be produced with high-quality materials and robust designs.

The electric motor does not need a so-called Hot Section Inspection, as is required for popular conventional combustion turboprop engines such as the PT6. It may, however, be expected that components like bearings will need to be replaced during the aircraft's lifetime and damages can occur by foreign particles/objects entering the motor. Since the lifetime of commercial aircraft is long and electric propulsion is at an early stage, the motor may as well be replaced with newer and more efficient technology after a certain time.

Taking advantage of the miniaturisation of modern electronics, the electric aircraft will employ—just as ground vehicles do today—a wide array of sensor systems that will track temperatures, vibration, and other relevant data in real-time to continuously monitor the condition of the motor. Maintenance and replacement of fan blades or propellers will be similar as for today's propulsion systems.

12.4 BATTERY COST

The batteries in commercial aircraft will be frequently replaced, depending on their lifetime. The lithium-ion batteries used for cars today can approximately cycle for 1 000 full-cycle times before their capacity is reduced to 80% of a new battery. (The definition of battery life is when capacity is reduced to 75 to 80% of a new battery.) While 1 000 cycles are sufficient for the lifetime of most cars, a regional commercial aircraft may fly 10 hours every day, and the batteries may have to be replaced two times every year, depending of the size of the battery pack.

To provide a quantitative example, assuming a battery cost of 100 USD/kWh, the hourly battery amortisation cost for this aircraft will be 250 USD/hour. For this reason, the battery systems selected for future electric aircraft are likely to be designed for a lifetime of 5 000 or more cycles.

That being said, the common cost reference USD/kWh is relevant for automotive and other industries, but for aviation, this cost reference has to be compared to battery cycle life to be fully applicable. Assuming a 50-seater aircraft with an average power consumption of 2,5 MW, a battery on board with a capacity of 2,5 MWh and a cycle life of 1 000, it will need to be replaced after 1 000 hours of flight. If the battery's new price is 100 USD/kWh, then the battery cost will be 250 USD/flight hour.

After finishing its service life in an aircraft, the battery is likely to be used in a secondary application, such as a battery bank. It is debated what value the battery will have at this stage, but it is of course likely to be more than zero and the cost for recycling will come at a later stage and be carried out by last user.

12.5 ENERGY COST

A pure electric aircraft will be subject to the grid and electricity costs in its respective market. The energy consumption for a pure electric aircraft can roughly be assumed to be less than one-third that of a conventional aircraft. If an electric aircraft consumes 3 kWh electric power a similar combustion engine aircraft will consume approximately 10 kWh (1 litre fuel) for doing the same job. The reason for this big difference is the high efficiency of electric propulsion compared to a combustion engine.

Let us now run some numbers. Including the CO₂ tax of 1,1 NOK/litre, the jet fuel price may be at 5 NOK/litre or even lower for the time being, depending on quantities. (The international commodity price level for jet fuel is today approximately 1 USD/gallon, having plummeted from 2 USD/gallon just one year ago). Looking at the Avgas 100LL price, this has not changed much and is still very expensive in the range of 18 NOK (2 EUR)/litre. The energy content is similar to jet fuel. The industrial electricity price in Norway remains at approximately 0,7 NOK (0,065 EUR)/kwh, including grid cost. Although this price may be slightly lower for some time during 2020, it is likely to be relatively stable at this level in the years ahead.

Jet Fuel Monthly Price - US Dollars per Gallon

Range 6m 1y 5y 10y 15y 20y 25y 30y

Aug 2019 - Jul 2020: -0.716 (-39.78 %)

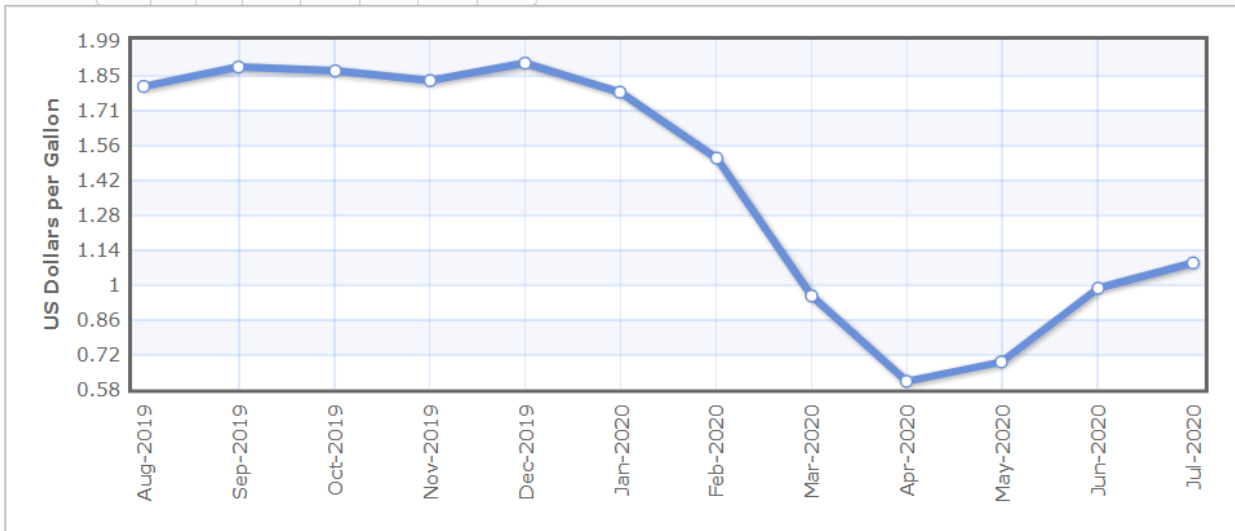

Description: U.S. Gulf Coast Kerosene-Type Jet Fuel Spot Price FOB

Source/credit: <https://www.indexmundi.com/commodities/?commodity=jet-fuel&months=12¤cy=nok>

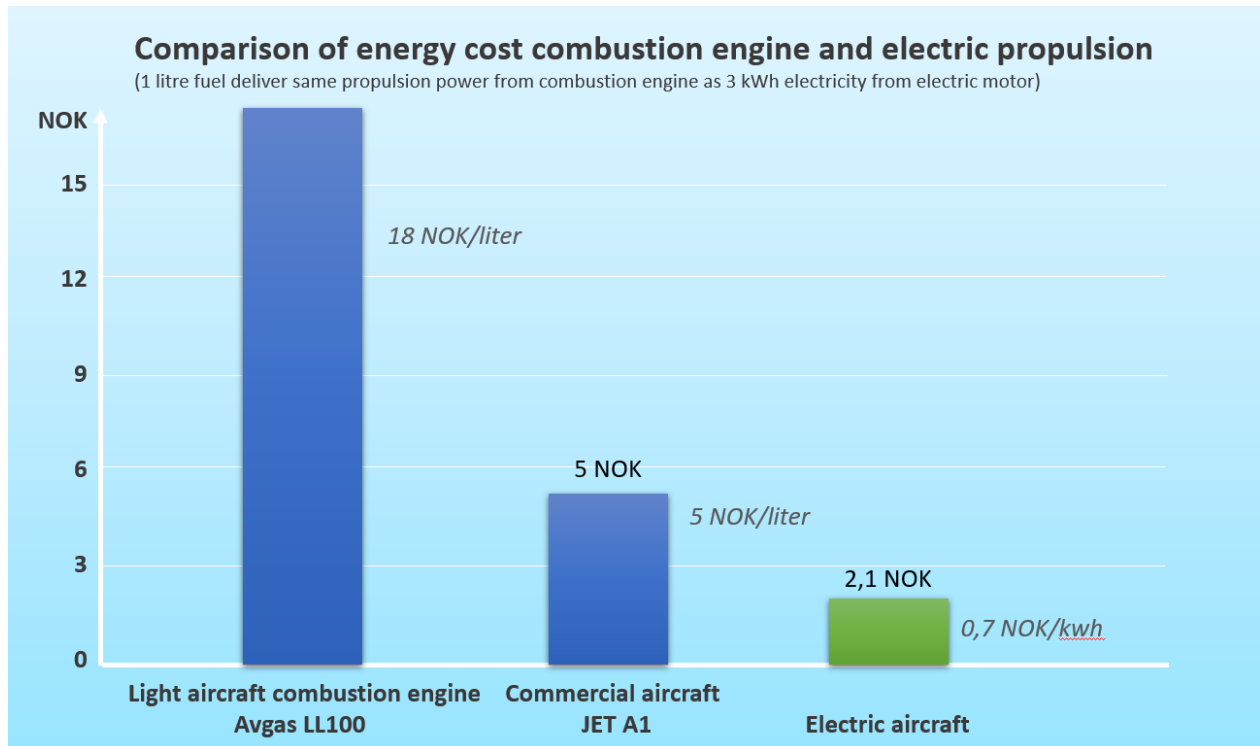

Comparison based on the conservative assumption that electric propulsion reduces energy consumption to 1/3 of a fossil fuel propulsion system. (Graphics by Green Future AS)

13. ELECTRIC AIRCRAFT DESIGN FOR NORWEGIAN REQUIREMENTS

13.1 SHORT FIELD OPERATIONS

Looking forward, an important infrastructure consideration for aviation in Norway is the current number of short field airports, defined by runways of 800 – 1 199 meters / 2 600 – 3 900 feet. These runways may need to be extended and upgraded to accommodate larger aircraft, which in general require longer runways for optimal operation.

If the development of this network can be limited to below 1 200 meters, this means a significantly lower investment and operation cost. If the runway length is above 1 200 meters, it will be under a much more comprehensive certification regime with a number of additional technical, administrative, and operational requirements.

Today, the Bombardier Dash 8-100, a mainstay of the Norwegian fleet, is operating on routes to these short field airports. In ten years' time, however, those aircraft will have to be replaced, prompting a discussion about whether it may be time to extend runways to provide flexibility for more types of aircraft.

Electric regional aircraft could change this short field airport calculus moving forward, especially given the other advantages already addressed to an extent regarding cost efficiency, low noise, et cetera. The electric aircraft would have the ability to operate on short runways at small airports in Norway, as well as across Europe and the United States. The current trend, where more and more traffic is centralized to the largest hub airports, may change when new efficient electric aircraft increasingly become available.

Electric propulsion may be more amenable to STOL (Short Take Off and Landing) designs than conventional aircraft propulsion technologies. Electric motors can be designed to provide short power boosts for acceleration and can also be reversed for braking after landing. For fixed wing aircraft, the wing must be designed accordingly to accommodate the desired STOL properties.

For more futuristic designs, such as tilting wing in combination with distributed electric propulsion, covered elsewhere in this study, there are expectations for even more extreme performance. Combinations of Vertical Take Off and Landing (VTOL) and STOL aircraft may become a reality for regional air traffic in the future.

By being an early adopter of electric aviation, Norway would be well-positioned to influence the design of electric aircraft to be suitable for operation on the Norwegian short field network of airports, as well as be prepared and engineered for the harsh climatic conditions in Northern Europe.



Røst airport and its 800-meter runway. (Credit: Ørjan Arntsen)

13.2 ELECTRIC AIRCRAFT AND NOISE

As described previously in this study, there are great expectations for noise reduction via the introduction of electric propulsion. Besides reducing air pollution, there also is a great desire to reduce noise “pollution” from aircraft. The noise created from today’s air transport limits the locations of airports and their hours of operation. At the very least, the noise from combustion engine aircraft is annoying, but the disruption and agitation the noise causes, especially if repeatedly occurring throughout the day, could pose a health hazard for neighbours of the airport. Noise reduction is therefore a high-priority parameter in any new engine designs.

For Light-Sport Aircraft activities and thousands of small airfields, electric propulsion thus comes as very good news. Noise from the first electric aircraft is not only reduced, but in many scenarios nearly eliminated. The dominant exhaust noise from piston engines is gone, and with proper propeller design, the noise from electric aircraft should be minimally disruptive.

The dramatic reduction of noise would enable the operating of airports for regional aircraft close to or from within local communities, or even inside densely populated cities. The elimination of turbine engines on turboprop regional aircraft should provide for noise reduction, with even more reduction anticipated from new, low-pressure ducted fan with electric motors.



Bodø airport, which is within walking distance from the city centre. (Credit: Tom Melby)

13.3 AIRCRAFT SIZE

It is likely that the first regional electric aircraft on the market around 2025 will be limited to a seating capacity of 9 to 19 passengers. Those aircraft will be mainly directed towards a market for short, on-demand or taxi flights, but may be equipped for scheduled traffic as well. Some evaluation has been made regarding if 19-seaters may work as an alternative for some of the routes on the short airfield network, and it is not unlikely that aircraft of this size can be used for many flights in combination with some larger aircraft. In the morning and evening, some destinations will need flights to serve more than 20 passengers at a time, but for many other destinations and times of day, 19-seaters should be sufficient.

13.4 COST RELATED TO INTRODUCTION

An immediate reduction of CO₂ emissions and direct energy cost will be available from day one with electric aircraft, but the potential for reduced overall operation cost may not be available before the technologies are established and more mature. It should also be expected that there will be slightly higher acquisition costs compared to a similar combustion engine aircraft, but the aircraft manufacturer may cover this premium in order to be competitive.

In addition to aircraft related cost there may be additional administrative costs, training of personnel, infrastructure, et cetera.

There is presently limited information available to do any quantification of cost other than related to energy consumption.

As pointed out several times it will be important that governments establish a framework of good incitements to encourage the transition as soon as possible to reduce CO₂ emissions. Time is of essence and every year counts.

13.5 REQUIREMENTS FOR INFRASTRUCTURE

ELECTRICITY

The transition to electric propulsion in the transport sector will change the requirements for the supply of electricity on the distribution grid. In the big picture, the total electricity consumption in Norway is nearly 150 TWh, and the energy consumption for all inland air transport is in the range of 5 TWh (corresponding to 500 mill litre Jet A-1 fuel). It should be noted that the total amount of energy needed for comparable number of flights and distances covered as at present would be lower because electric power conversion is more efficient than conversion from fossil fuels.

Statnett, the state-owned system operator for the Norwegian electric grid system, considers that the electrification of aviation would have a limited influence on the national supply and transmission grid. But Statnett does confirm that it will be necessary to invest in local grids in order to ensure sufficient supply to the different airport locations.

To take an example: Trondheim airport has a yearly fuel sale in the range of 60 mill litre jet fuel (600 GWh energy). If 20% of the fuel sale were exchanged with an electric power supply to electric aircraft, the airport will need an average continuous power supply of approximately 5 MW.

Delving deeper, a 50-seater regional aircraft with a battery of 3,5 MW may require an instant power of 10 MW for fast charging. For each airport, then, it must be taken into account if this amount of power can be made available directly from the grid, or if a battery bank would have to be installed. If the aircraft were using a battery swap system instead, this setup would reduce the required level of instant grid power because the battery charging can be done over a longer time interval.

A similar challenge is recognized for the Norwegian car ferries that are already in commercial service. In the case of some of the ferry operators, the charging power of 2 to 3 MW is drawn directly from the grid, while others are using battery banks where sufficient power is not easily available.

Based on the assumptions above, the requirement for grid power for electric aviation per airport is likely to be in the range of 1 to 10 MW.

FUTURE AIRPORT INFRASTRUCTURE

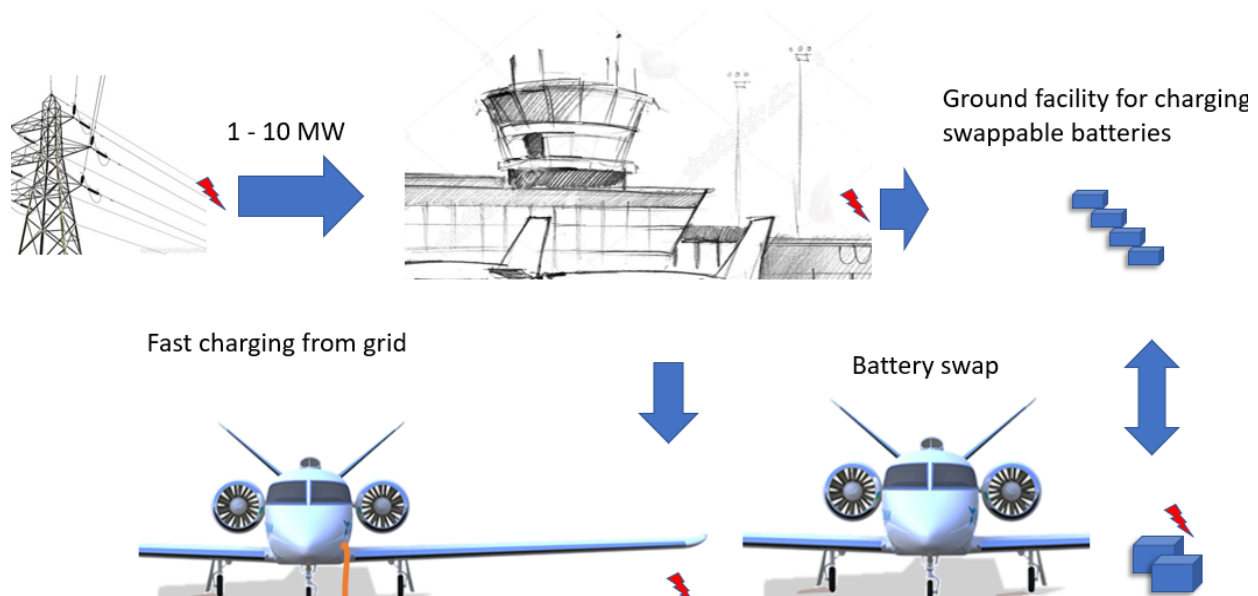

Airport infrastructure and charging options. (Illustration: Green Future AS)

OTHER INFRASTRUCTURE

If electric aircraft are equipped with systems for battery swapping, this will require an in-house charging facility as well as transport/lifting equipment to move batteries around. For fast charging, there may be special equipment needed to establish safe connections between the aircraft and the charge-supplying infrastructure, again handled by trained, dedicated personnel. A battery bank would likewise require bespoke infrastructure. In all cases, trained, dedicated personnel will be required for operating this equipment.

13.6 FIRST IMPLEMENTATION OF ELECTRIC AIRCRAFT IN NORWAY

The Stavanger – Bergen route is an ideal short distance and the airports should easily be able to establish necessary infrastructure to prepare for the first implementation of electric commercial aviation operation. The Civil Aviation Authority of Norway (Luftfartstilsynet) is prepared and ready to be engaged as early as possible to be involved together with the aircraft manufacturer, operator, and airport owner Avinor.

The arrival of the first electric aircraft, the Alpha Electro from Pipistrel, has been very useful for the various relevant personnel to acquire a basic understanding of electric aircraft operation, charging, and maintenance. Even though the Alpha Electro is a small aircraft, it is fully equipped for professional pilot training and features remote monitoring of all data related to power consumption and charging. The aircraft represents a promising first step into the future of aviation in Norway, as well as the rest of the world.

For commercial operation of the Norwegian short airfield network, there are more than 20 destinations/routes with distances ranging from 38 – 170 km, all of which can easily be flown by pure-electric propulsion. The first electric aircraft to operate this network may be configured as hybrid electric but be operated by electric power only as airports will have charging capability available. For a few destinations, the aircraft can continue to the next airport or return to its origin without charging and still fly electric because, again, the distances are fairly short. With the flexibility of the hybrid electric aircraft, the implementation can be made step-by-step to reduce the risk of irregularities during the introduction phase.

13.7 DAILY OPERATION AND CHARGING

In collaboration with Avinor and based on information from Widerøe, several daily flight programs for individual aircraft have been examined in order to understand the requirements for such an operation. Some of the aircraft have a day program of up to nearly 12 hours block time and more than 20 flights. The shortest scheduled turnaround time is down to 15 minutes.

It will be important to establish goals for performance criteria for new electric aircraft and infrastructure at a similar level. The bottleneck is the available time for charging a battery or performing a battery swap, but these solutions should be achievable both from a technical and a temporal perspective.

14. ROUTE STAVANGER – BERGEN

The route between Bergen and Stavanger is ideal for the introduction of electric aircraft in Norway. The route connects the 2nd and 4th largest cities in Norway and the distance is less than 180 km. This route is today operated by different airlines with a time that varies from 25 to 40 minutes, according to Planemapper data (5). In order to understand what an electric flight for this route would look like, Alessandro Sgueglia from AURA-AERO has made a simulation.

Variable	Value	Source
Maximum takeoff weight	8618 kg	Max limit CS-23 (6)
Wing area	29.5 m ²	Computed from CS-23 specification ¹
Max LoD	16.5	Estimated from similar aircraft
Battery specific energy	500 Wh/kg	2025 technology perspective (7)
Range	180 km	Bergen-Stavanger distance



The simulation indicates an optimal cruising altitude of 4 500 feet or 1 500 meters. In some weather conditions, however, this may be too low, but the energy consumption and flight time may not change much if a higher cruising altitude is selected. The energy to climb higher can be exchanged to distance during descent. The energy consumed on a Stavanger – Bergen flight in normal weather is below 500 kWh for a 19-seater. Flight time is simulated to be in the range of 35 to 40 minutes, while turnaround time at each end station may be less than 30 minutes, including charging, utilizing a 2 MW charger 500 kWh that may be “refilled” in 15 minutes. This charging power will be similar to what is already available today for electric cars where a sub-100 kWh battery can be charged with 350 kW power.

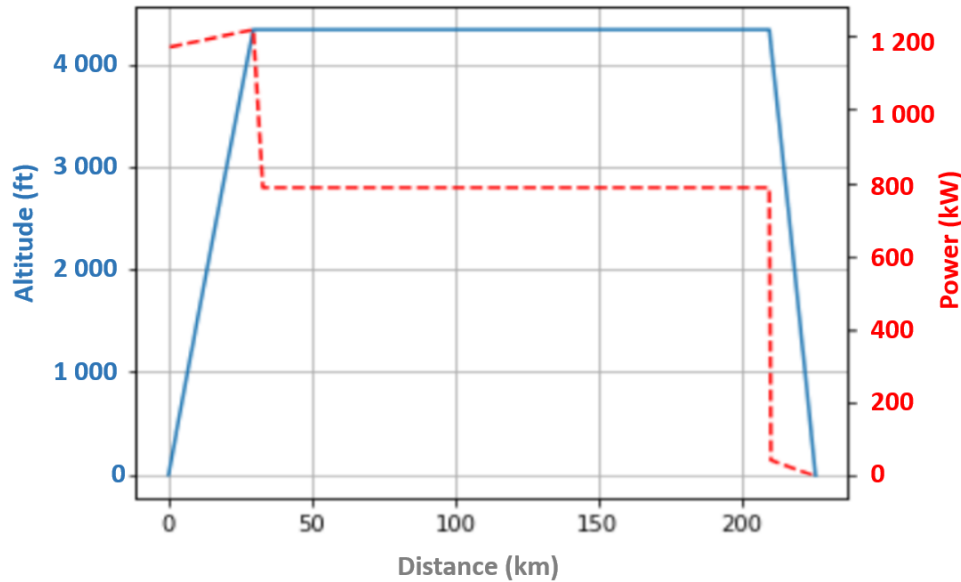

Optimal trajectory for Bergen-Stavanger route. (Credit: Aura-Aero)

The optimal flight parameters are found in the table below. One of the most sensitive parameters is speed as the energy consumption is exponential to this parameter. But because speed helps produce the desired reduced travel time benefit of air travel, speed should not be compromised by going below 400 km/h.

Cruise speed	400	km/h
Cruise altitude	4085	ft
Rate of climb	945	ft/min
Rate of descent	-1735	ft/min
Energy consumption	445.9	kWh
Flight time	34.1	min

Results of the trajectory optimisation for the Bergen-Stavanger route

References:

1. NASA. OpenMDAO website. [Online] 2020. <https://openmdao.org/>.
2. Multidisciplinary Design Optimization: A Survey of Architectures. Martins, Joaquim and Lambe, Andrew. 9, s.l. : AIAA, 2013, AIAA Journal, Vol. 51, pp. 2049-2075.
3. Sgueglia, Alessandro. Methodology for sizing and optimising a Blended Wing-Body with distributed electric ducted fans. Toulouse : PhD dissertation, ISAE-Supaero, 2019.
4. Multidisciplinary design optimization framework with coupled derivative computation for hybrid aircraft. Sgueglia, Alessandro, et al. 4, s.l. : AIAA, 2020, Journal of Aircraft, Vol. 57, pp. 715-729.
5. Planemapper. Bergen-Stavanger route. Planemapper. [Online] 2020. <https://www.planemapper.com/flights/DY122>.
6. EASA. CS-23 Normal, Utility, Aerobatic and Commuter Aeroplanes. s.l. : EASA, 2020.
7. Sgueglia, Alessandro, Dubreuil, Sylvain and Bartoli, Nathalie. Civil Aircraft Vehicle Design. [book auth.] Loic Brevault, Mathieu Balesdent and Jerome Morio. Aerospace System Analysis and Optimization in Uncertainty. s.l. : Springer Optimization and Its Applications, 2020, pp. 361-384.
8. Hepperle, Martin. Electric flight: potential and limitations. s.l. : Workshop on energy efficient technologies and concept operation, 2012.

9. IATA. IATA Technology roadmap. s.l. : IATA, 2013.

10. Aircraft Technology Roadmap to 2050. s.l. : IATA, 2019.

15. TIMELINE

During the work on this study, different scenarios of timelines have been indicated by the various research papers and organizations involved with electrification. For startups, it is important to move fast in order to commercialize and get income as soon as possible. For the established aviation industry, it is instead more a balance of not moving too fast while testing new solutions thoroughly, yet also not moving too slowly and being left behind the competition and overtaken by newcomers. As seen from the example of the automotive industry and Tesla, it is possible for newcomers to take a lead even in established industries.

Over the last year, it has become clearer that the entire aviation industry is serious in its efforts at electrification and to address the strong political demand to shift into less-polluting means of air transport. An increasing number of projects and activities have started and are backed by serious funding. As noted previously in this study, it should be expected that more announcements like the Airbus, Siemens, and Rolls Royce collaboration to develop electric propulsion for aircraft will soon be made.

Certification does remain a critical factor moving forward. But seeing as those companies and individuals with top expertise in aircraft engineering, together with approval authorities, all have the same goal of safe and emission-free flight, this high-priority electrification work should make tremendous strides in the near future.

The COVID-19 situation has for sure not improved the short-term timeline, but it seems not to have changed the overall determination toward bringing about the electrification of aviation. The investment in research may even be increased, with the result that the influence on the longer-term timeline is likely insubstantial.

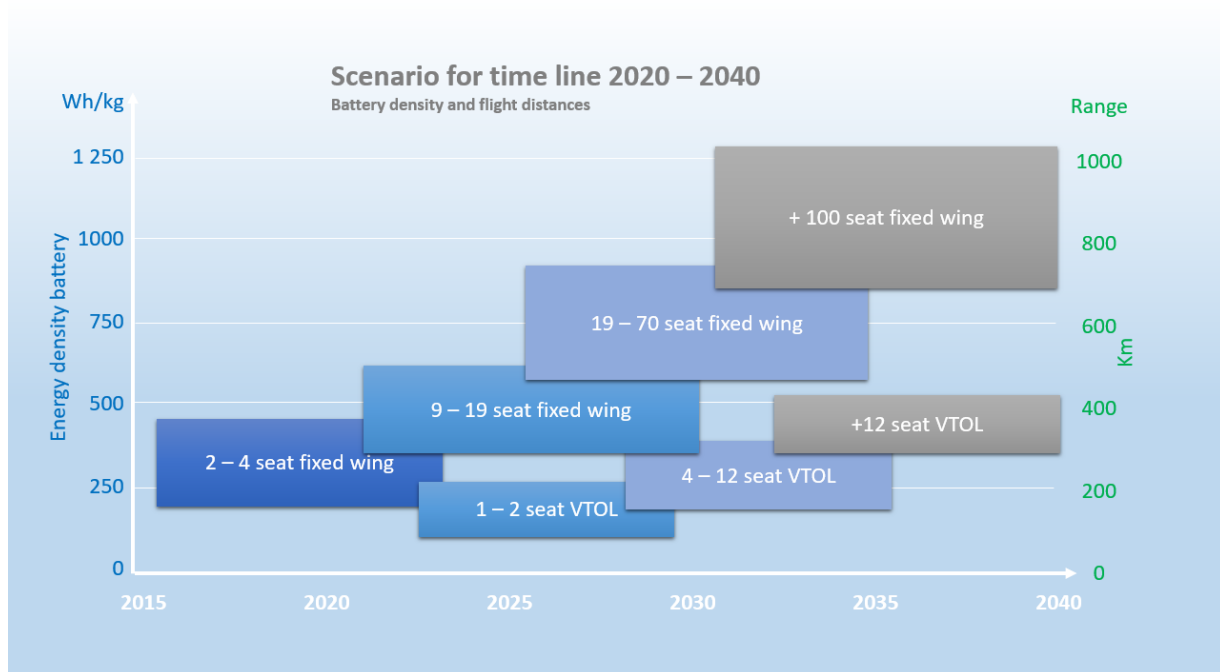

Scenario for development of electric aircraft with reference to battery density and comparable range. (Credit: Green Future AS)

The illustration below indicates the status for some of the projects today, where just a few electric airplanes have taken to the sky so far. The time from test flight to certification is normally not less than three years, though for a retrofitted aircraft, it may be less.

Status test flight and certification process

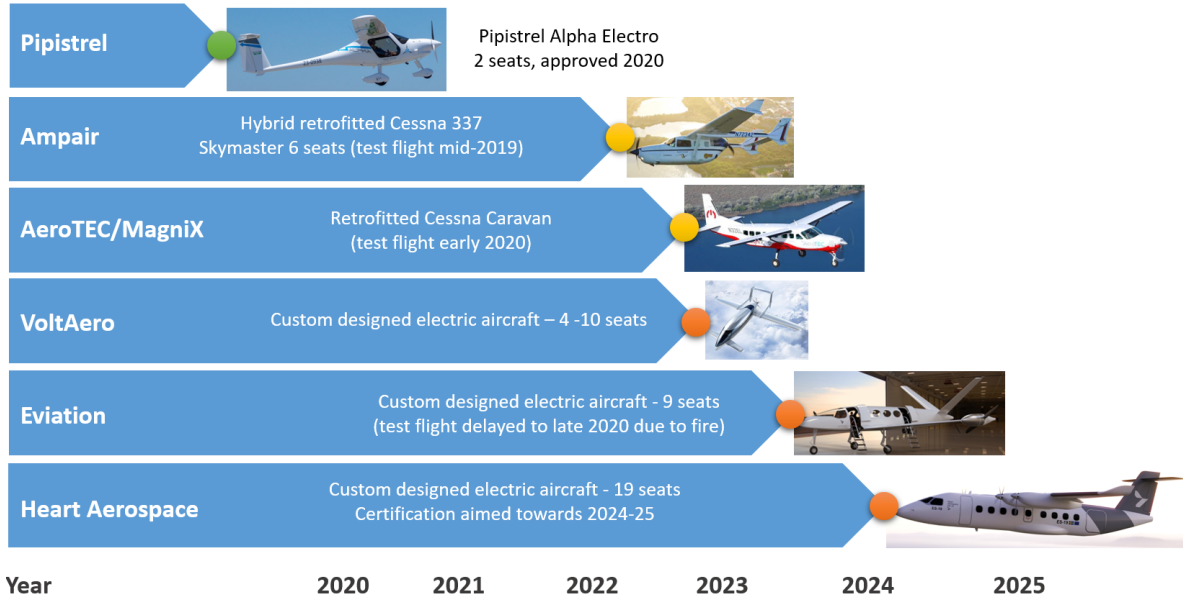

Test flight status and estimated possible certification year for various aircraft. (Illustration by Green Future AS)

16. RISK

This study has solely focused on the opportunities provided by the electrification of aviation. There are several risks associated with this development that may affect the timeline, cost, and efficiency. Mainly the risk is connected to either technical or financial risk, but there is also political risk associated with changing priorities.

Technical and compliance risk

For different reasons, there can be delays caused by slower progress in battery development than anticipated today. Systems may not achieve the expected performance and be less efficient than anticipated. There may be technical challenges making it difficult to reach the necessary redundancy and safety level required from certification standards.

Financial risk

Startups do not get the necessary funding, or in larger organizations, investment programs may be stopped. Development may become more expensive, components more expensive, and operation more expensive.

Political risk

There is today a strong political drive towards renewable energy and reduced emission with strong initiatives benefitting the environment. The development of electric aviation will depend on a continued political drive in this direction.

Pandemic risk

The COVID-19 pandemic has clearly demonstrated a risk factor that was not mentioned in the prior version of this study. Such a pandemic as we are experiencing has a fundamental influence on daily life, revealing how vulnerable the global society is to major disruption.

Climate risk

Just as COVID-19 pandemic is demonstrating how we are all at the mercy of a virus, the pandemic may be a “wake up call” for global climate change, showing how serious we should address climate risk.

17. FURTHER WORK

It will be important to continue the dialogue with the aircraft manufacturers and potential aircraft operators to maintain a focus on important specifications and performance metrics in order for new aircraft to be able to operate on the Stavanger – Bergen route and in the Norwegian short airfield network in general.

Statnett and regional electric grid operators should also be made aware of the expected requirements for electric supply to the different airports to make sure that this is considered in their future plans.

As important or maybe the most important activity in short term is to continue the work to encourage politicians and governments to prepare a framework of good incentives to encourage the transition as soon as possible to reduce CO₂ emissions. Time is of essence and every year counts.